



Model 400

Non-Electric Dry Chlorine Pellet Feeder

Installation & Operation Information

Table of Contents

Installation and Operation.....	1
Theory of Operation.....	2
Approximate Chlorine Concentration Per Pump Cycle.....	2
Calculating Chlorine Concentration Per Pump Cycle.....	3
Chlorine Setting in PPM for Center Tube & Cap.....	4
Refilling Information and Part Identification.....	5
Model 400 Feeder - Trouble Shooting.....	6

THE MANUFACTURER EXPRESSLY DISCLAIMS AND SHALL HAVE NO LIABILITY WHATSOEVER IN EXCESS OF THE PURCHASE PRICE OF THE MODEL 400 FEEDER FOR ANY LOSS, DAMAGE OR INJURY TO PERSON OR PROPERTY, INCLUDING ANY SUCH LOSS, DAMAGE OR INJURY ATTRIBUTABLE TO MANUFACTURER'S NEGLIGENCE OR FAULT AND INCLUDING ANY INCIDENTAL OR CONSEQUENTIAL DAMAGES, from (a) the design, manufacture, sale, delivery, installation, repair, operation or use of the Model 400 feeder or any part thereof, (b) any actual or alleged failure or defect in the Model 400 feeder or any part thereof, or (c) any actual or alleged breach or non-performance by the manufacturer. Some states do not allow the exclusion or limitation of incidental or consequential damages, so the above limitation or exclusion may not apply to you.

Installation & Operation Information

The **Model 400** feeder will operate on a varying pressure such as a home well system or on a constant pressure such as a sprinkler or pool system.

When used as a varying pressure system the non-functioning valve (No. 11) must be in place as received. A charcoal filter must follow the **Model 400** feeder on a varying pressure system for proper operation. Tests have shown that one cube of coconut shell activated carbon is the best carbon to use (grade 9/50, mesh 8/30).

There are seven positions for varying the amount of chemical feed. Rotate the top cap (No. 7) so there is a hole showing through the level desired. There are two hole selections for each hole in the cap (No. 7).

The smaller hole will dispense the greatest amount and selecting a lower hole on the cap will increase the output.

Approximate chlorine readings using a 42 gallon pressure tank out of the **Model 400** feeder per pump cycle in PPM, for each hole are; 1=2, A=3.5, 2=:8, B=13, 3=30, C=40 and with no holes showing, the off position is 60 plus.

These readings are obtained with no iron or hydrogen sulfide using the chlorine. Variables that will change the

dilution are: pressure tank size, large volumes of water flow while the pump is building pressure to shut off, horse power of the pump, and a water logged pressure tank or air pressure is low or high in the air bag. **The Model 400 feeder will dispense the same amount of chemical for each cycle of the pump from maximum to minimum pressure.**

When used on a constant-pressure and flow it is necessary to replace the valve (No.11). Replace it with the optional adjustable valve (No. 20). It may be necessary to install the optional screen filters (No. 19) in the top inside hole of (No. 8) and screen (No. 18) in the adjustable inlet hole when using chemicals other than chlorine, When using the unit for constant pressure and flow such as a sprinkler system or pool; install the unit on the output to the sprinkler heads or on the return line to the pool. The adjustments for the constant pressure system should have no holes shown through in the off position. The amount of chemical dispensed is controlled with the adjustable rate of feed valve on the outside of the unit. It may be necessary to adjust the unit if flow is increased or decreased.

(Actual size of the **Model 400** Feeder - 10.5" high X 11.5" long) (Empty weight - 6.5 lbs.)

MAXIMUM TESTED PRESSURE IS 80 LBS.

**U.S. PATENT NOS. 5,053,206; 4,908,190;
4,548,228; 4,407,322**



WARNING: Use Only Calcium Hypochlorite Chlorine Tablets For Potable Water.



NOTE: Install a Check Valve After the Pressure Tank For Heavy Use of an Irrigation Valve.

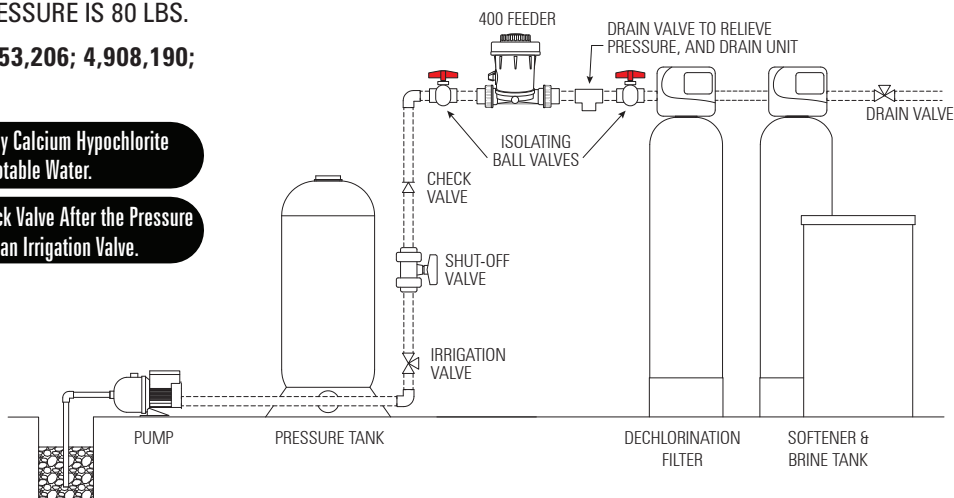

DANGER: Do Not Mix Different Types or Brands of Chlorine, an Explosion Can Occur.

Theory of Operation

After filling the unit with chemical to no higher than the bottom of the adjustable cap or less and returning water flow, fluid will flow into the chemical container mixing with the chemical until the air trapped in the top of the unit is compressed to the same pressure as the line pressure. When the line pressure is reduced, compressed air in the air chamber will force fluid from the container down and up through the outside center tube and down the inside tube to the water line until pressure is equal or until the fluid level reaches the hole that is open in the outside tube. At that time the compressed air will flow through the hole into the outside tube, down the inside tube and no more fluid will flow. This procedure will occur on each pump cycle. The outside tube has six (6) holes with three of them smaller. The cap can be rotated to select either a

large hole or a small hole in six different locations. During fluid flow a small amount of fluid will flow through the hole selected thereby diluting the fluid flowing up through the outside tube. Most chemical solutions are heavier than water and the top of the fluid is not as heavily saturated as the bottom of the container. Selecting a small hole will increase the chemical concentration and selecting a lower hole increases the solution output.

The unit can be used as a venturi operation for operations other than varying pressure. In this mode the cap may be rotated so there is no hole through the outside tube or left with the hole through the outside tube to help dilute the fluid if needed. The chemical solution out is controlled with the optional rate of feed valve in a constant pressure system.

Approximate Chlorine Concentration Per Pump Cycle

To oxidize one PPM of Hydrogen Sulfide (H_2S), it takes 2.2 PPM of Chlorine (Cl_2). To oxidize 1 PPM of Iron (Fe) it takes .64 PPM of Cl_2

Example: If you have 4 PPM of Fe and 1 PPM of H_2S , look on the vertical portion of the graph labeled PPM and start at 4 and move horizontal to the line marked Iron - Fe X .64 Cl_2 and then down to the bottom of the graph marked Chlorine - Cl_2 PPM. It should intercept the bottom about 2.6. This is the amount of Cl_2 needed to oxidize 4 PPM of Fe. Now look on the vertical portion of the graph labeled PPM and start at 1 and move horizontal to the line marked Hydrogen Sulfide - H_2S X 2.2 Cl_2 and then down to the bottom of the graph. It should intercept the bottom about 2.2. This is the amount of Cl_2 needed to oxidize 1 PPM of H_2S .

Example in dotted lines:

4 PPM Fe requires 2.6 PPM of Cl_2

1 PPM H_2S requires 2.2 PPM of Cl_2

Total Cl_2 required is 2.6 plus 2.2 = 4.8 PPM Cl_2

If using a 42 gallon pressure tank, the No. 2 hole on the **Model 400** feeder should be used. This will dispense about 8 PPM of Cl_2 and a filter with one cube of activated carbon after the unit will eliminate the excess Cl_2 . If using the **Model 400** feeder for iron removal or extremely high H_2S , it is necessary to use a back washing valve on the carbon filter.

Higher PPM than the graph can be calculated.

Example:

$$20 \text{ PPM } H_2S \times 2.2 \text{ } Cl_2 = 44 \text{ PPM of } Cl_2$$

$$20 \text{ PPM Fe} \times .64 \text{ } Cl_2 = 12.8 \text{ PPM of } Cl_2$$

The **Model 400** feeder will hold about 4 pounds of Cl_2 (10 gram tablets). If it is adjusted to the No. 1 hole, and using a 42 gallon pressure tank with one cube of activated carbon the system should process approximately 20,000 gallons of water before the unit would need refilling.

Calculating Chlorine Concentration Per Pump Cycle

Approximate **Model 400** Feeder Cl_2 Concentration Per Pump Cycle for a 42 Gallon Pressure Tank.

- | | |
|---------------|-------------|
| 1 = 2 PPM | A = 3.5 PPM |
| 2 = 8 PPM | B = 13 PPM |
| 3 = 30 PPM | C = 40 PPM |
| OFF = 60+ PPM | |

If Using an 82 Gallon Pressure Tank Divide the PPM By 2

If Using a 20 Gallon Pressure Tank Multiply the PPM By 2

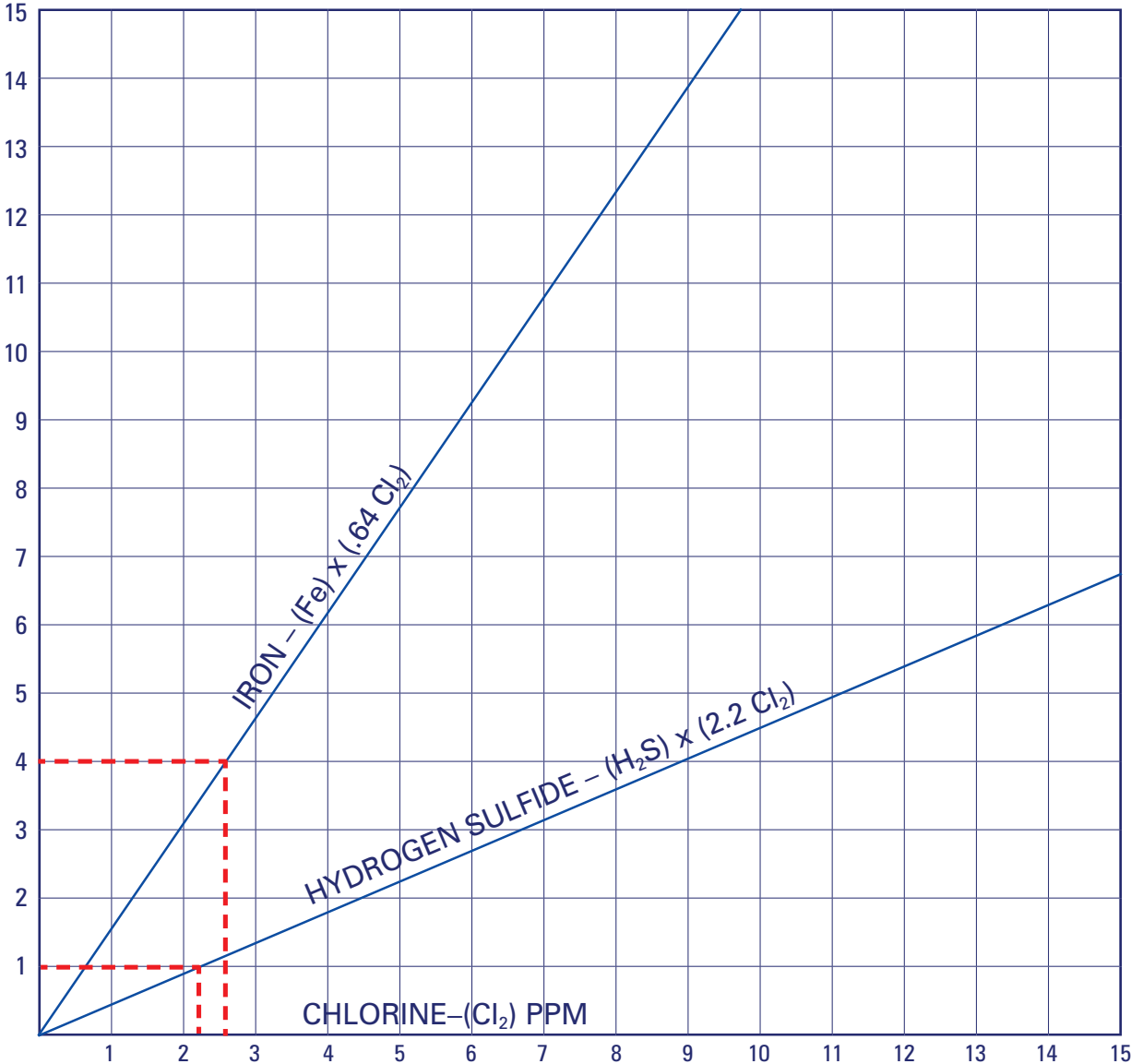

Chlorine Setting in PPM for Center Tube & Cap

Hole Settings in Parts Per Million

HOLE # 1 = 2 PPM
HOLE # A = 3.5 PPM

HOLE # 2 = 8 PPM
HOLE # B = 13 PPM

HOLE # 3 = 30 PPM
HOLE # C = 40 PPM

All Holes Closed Will Deliver
60 PPM Per Pump Cycle.

This chart is for a 42 gallon or equivalent pressure tank. When using an 80 gallon pressure tank, the PPM amount will be 50% less per pump cycle. A 20 gallon pressure tank will yield 2 times the amount.

Each number or letter will show a different hole in the cap. Line up the 3 holes in the cap with the proper number or letter directly under it (as per figure 1). The hole in the tube should show in the center of the hole in the cap.

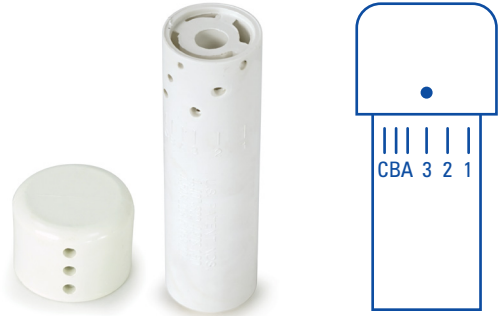

CAUTION: UNIT MUST BE INSTALLED AFTER THE PRESSURE TANK

U.S. PATENT NOS.
5,053,206; 4,908,190;
4,548,228; 4,407,322

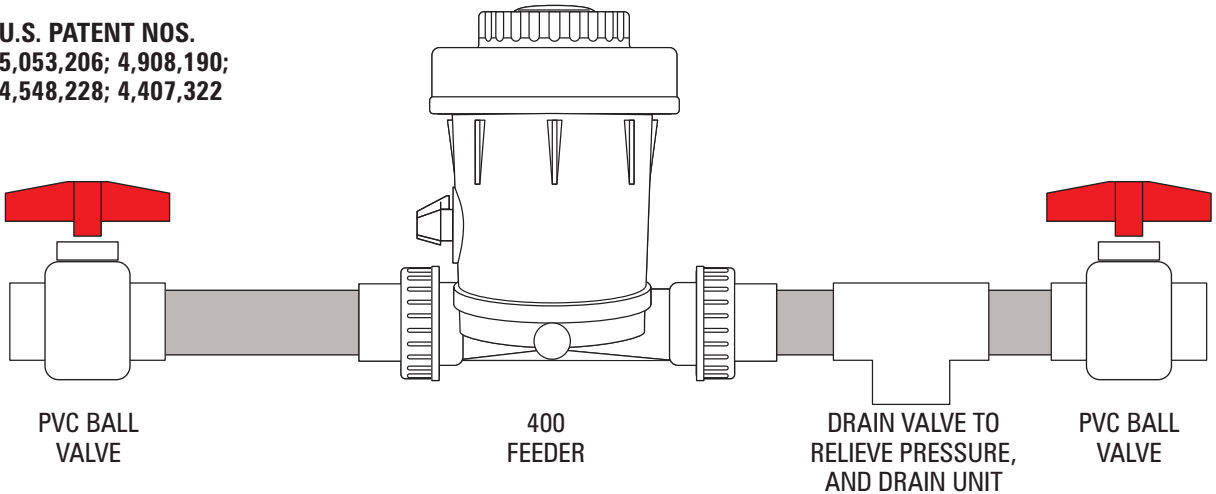

CAUTION: When Draining Chlorine, Chlorine Can Bleach Clothing & May Burn Eyes & Skin.

Center Tube Must be Removed and Cleaned Each Time Before Refilling. (See filling information #3)

When removing center tube for cleaning, check hole setting in cap.

After cleaning, be sure the setting is the same before replacing cap.

Install PVC Check Valve Before Feeder if Untreated Water is Used Before Feeder.

Refilling Information & Part Identification

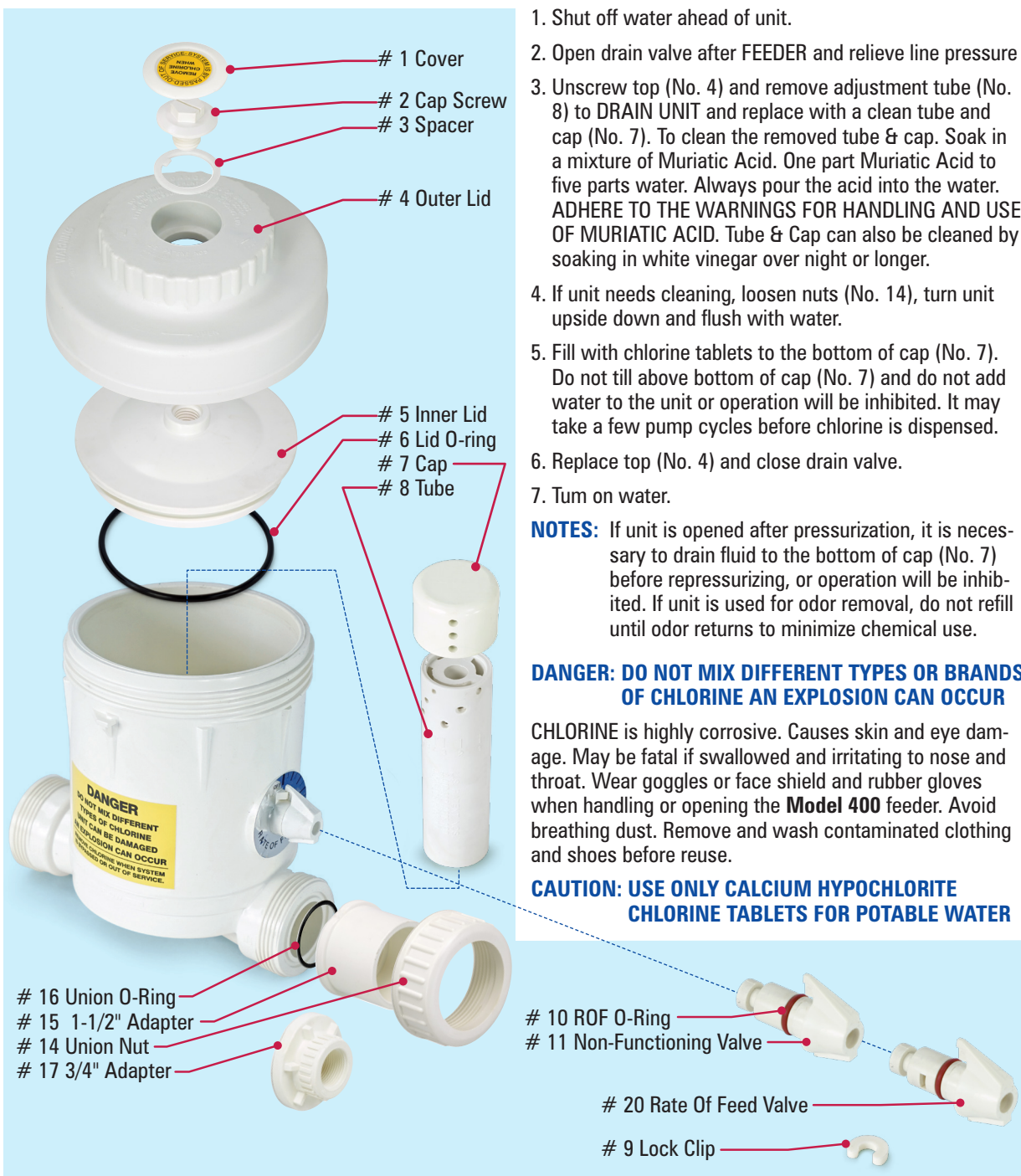

1. Shut off water ahead of unit.
2. Open drain valve after FEEDER and relieve line pressure
3. Unscrew top (No. 4) and remove adjustment tube (No. 8) to DRAIN UNIT and replace with a clean tube and cap (No. 7). To clean the removed tube & cap. Soak in a mixture of Muriatic Acid. One part Muriatic Acid to five parts water. Always pour the acid into the water. ADHERE TO THE WARNINGS FOR HANDLING AND USE OF MURIATIC ACID. Tube & Cap can also be cleaned by soaking in white vinegar over night or longer.
4. If unit needs cleaning, loosen nuts (No. 14), turn unit upside down and flush with water.
5. Fill with chlorine tablets to the bottom of cap (No. 7). Do not fill above bottom of cap (No. 7) and do not add water to the unit or operation will be inhibited. It may take a few pump cycles before chlorine is dispensed.
6. Replace top (No. 4) and close drain valve.
7. Turn on water.

NOTES: If unit is opened after pressurization, it is necessary to drain fluid to the bottom of cap (No. 7) before repressurizing, or operation will be inhibited. If unit is used for odor removal, do not refill until odor returns to minimize chemical use.

DANGER: DO NOT MIX DIFFERENT TYPES OR BRANDS OF CHLORINE AN EXPLOSION CAN OCCUR

CHLORINE is highly corrosive. Causes skin and eye damage. May be fatal if swallowed and irritating to nose and throat. Wear goggles or face shield and rubber gloves when handling or opening the **Model 400** feeder. Avoid breathing dust. Remove and wash contaminated clothing and shoes before reuse.

CAUTION: USE ONLY CALCIUM HYPOCHLORITE CHLORINE TABLETS FOR POTABLE WATER

Model 400 Feeder - Trouble Shooting

SYMPTOMS	REMEDIES
Definition of Pump Cycle	(From the time the pump shuts off until the time the pump turns on). The amount of water dispensed is depended on the size and differential pressure of the pressure tank. The Model 400 feeder dispenses the same amount of chemical for each pump cycle regardless of pressure tank size or differential pressure settings.
Lid is hard or impossible to remove (No. 4)	Line pressure has not been relieved. Unit was not previously cleaned when re-filled and inside tube is plugged (No. 8). The unit is under pressure. Be extremely careful when removing a lid under; pressure. It can blow off with extreme force.
Low pressure or low water flow after carbon tank.	Carbon fouled and needs back washing or replaced
Tube (No. 8) appears warped or melted.	Do not mix different types or brands of chlorine. Make sure no oil or petroleum products mix with the chlorine.
Chlorine smell after carbon, and/or Unit appears to be using chemical too fast.	No carbon or carbon tank is internally bypassing or carbon is fouled with oxidized iron
	Pressure tank is water logged or pressure is low or high in the air bag
	Improper Model 400 feeder adjustment or adjustment holes are plugged and need cleaning. Tube (No. 8).
	Improper pressure switch adjustments. There should be a minimum differential pressure of 20 PSI.
	The chart for chlorine output is for a 42 gallon pressure tank. If using a smaller tank such as a 20 gallon tank, cut the chlorine output by one half. The Model 400 feeder will output the same amount of chemical for each pump cycle and a smaller tank is delivering less water on each pump cycle increasing the chemical concentration.
High odor. and/or Unit appears not to be dispensing the proper amount of chemical.	Unit needs chlorine or it is over filled. (Max. 3/4 full)
	Wrong Chlorine. Only calcium hypochlorite tablets will dispense high amounts of chlorine. Stabilized chlorine is not approved by the FDA for potable water.
	Pump continues to run and not cycling on and off due to large volume of water flow or pump is too small for demand. No chemical will dispense when the pump is running.
	Pressure was released from the unit and fluid was not removed from the unit before re-pressurizing the unit.
	Carbon tank internally bypassing.
Low or occasional odor. and/or Unit appears not to be dispensing the proper amount of chemical	All of the above for high odor.
	The chart for chlorine output is for a 42 gal. pressure tank. If using an 82 gal. tank, double the chlorine output from the Model 400 feeder. The Model 400 feeder will output the same amount of chemical for each pump cycle and a larger tank is delivering more water on each pump cycle-and decreasing the concentration.
	Wrong amount of carbon, one cube minimum.
Extra high odor.	Unit needs to be adjusted for a greater chlorine output.
Odor only in the hot water.	Magnesium anode rod in the hot water tank. Remove the rod. Check: Technical Paper 26-62 Water Conditioning Foundation 1201 Wausegan Road, Glenview, Illinois