

# *Quick Change, Twist & Loc* Reverse Osmosis System OWNERS MANUAL



**Installation,  
Operation & Maintenance**



**NOTE:**

Please read through the instructions carefully before using or installing the product and ensure that the manual is kept in a safe place for future reference. The system must be properly installed and located in accordance with the installation instructions before it is used.

# Safety Instructions

## **Attention Twist-Loc RO Water Filtration System Customer**

The RO System filters multiple substances harmful to humans and pets including impurities, residual chlorine, heavy metals, chemicals, filterable viruses to name a few, and also removes 96 percent of ions in the water.

This system is intended for use on potable water supplies. Do not use where water is micro-biologically unsafe or with water of unknown quality. If bacterial contamination is present, a recognized method of water disinfection is required.

The RO Water Filtration System contains a replaceable reverse osmosis membrane filter which is critical for the effective reduction of Total Dissolved Solids. The filtered water should be tested periodically to verify that the system is performing properly.

## **SAFE PRACTICES**

Throughout this manual there are paragraphs set off by special headings.

Note: Note is used to emphasize installation, operation or maintenance information which is important, but does not present any hazard. Example :



**NOTE:** The nipple must extend no more than 1 inch above the cover plate.

Caution: Caution is used when failure to follow directions could result in damage to equipment or property. Example :



**CAUTION!** Do not over tighten.

## **SAFETY PRECAUTION**

- This appliance can be used by children aged from 8 years and above and persons with reduced physical, sensory or mental capabilities or lack of experience and knowledge if they have been given supervision or instruction concerning use of the appliance in a safe way and understand the hazards involved. Children shall not play with the appliance. Cleaning and user maintenance shall not be made by children without supervision.
- Children should be supervised to ensure that they do not play with the appliance.

If you need additional information, please visit our website [www.nelsencorp.com](http://www.nelsencorp.com)

# Specifications

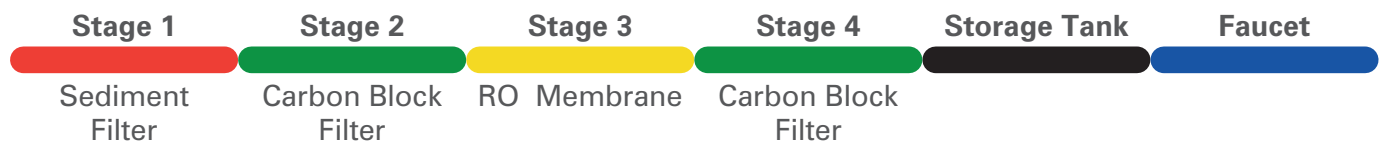

## SYSTEM DETAILS

Gallons per day (L/day)*	30.65 GPD (116.02 L/DAY)
Typical System Flow Sequence	Sediment Filter ➔ Carbon Block Pre-filter ➔ Reverse Osmosis Membrane ➔ Storage Tank ➔ Carbon Block Post-filter ➔ Dispensing Faucet
Sediment Filter (Stage 1)	5 Micron
Carbon Block Pre-filter & Post-filter (Stage 2&4)	Carbon Block 5 Micron
Reverse Osmosis Membrane (Stage 3)	Thin Film Composite
Storage Capacity	Plastic Coated Metal – Capacity 3.2 Gallon (12 Liters)

## Replacement Cartridges\*\*

	PURPOSE	MICRON RATING	CAPACITY	FLOW RATE	RATED LIFE	STAGE
Sediment Filter <b>PART# TWIST-SEDIMENT</b>	Sediment Reduction	5	2500 Gallons (9463 Liters)	0.5 gal/min	6 Months	1
Carbon Filter <b>PART# TWIST-CARBON</b>	Chlorine, Taste & Odor	5		1.9 liters/min		2 & 4

	PURPOSE	RECOVERY (PRODUCT WATER)	EFFICIENCY RATING	TDS REDUCTION	RATED LIFE	STAGE
RO Membrane <b>PART# TWIST-MEMBRANE-75</b>	TDS Reduction	30.57%	18.73%	91.1%	24 Months	3

\* The stated product performance is based on data taken after 30 minutes of operation at the following test conditions: 2,000 mg/L NaCl solution at 225 psig ( 1.5 MPa) applied pressure, 15% recovery, 77° F (25° C), pH 6.5–7.0

\*\* Rated Life and Capacity are dependent on local water conditions and level of pre-filtration.

The disposable filter cartridges must be replaced every 6 months and 24 months for the system membrane, at the rated capacity or if a noticeable reduction in flow rate occurs.

Performance of the reverse osmosis membrane is affected by several factors which must be considered when judging the condition of the system. The main factors which affect system performance are pressure, temperature, total dissolved solids level, recovery and pH.

## Components

### **MANIFOLD**

- 1 Filter Head
- 2 Inlet
- 3 Outlet
- 4 Tank line

### **REPLACEMENT CARTRIDGES**

- 5 Sediment Filter 13" (TWIST-SEDIMENT)\*
- 6 Carbon Block Filter 13" (TWIST-CARBON)\*
- 7 RO 75GPD membrane (TWIST-MEMBRANE)\*
- 8 Flow Regulator to Drain

### **INSTALLATION KIT**

- 9 Storage Tank
- 10 Faucet & Hardware
- 11 Tank Ball Valve



### **System Dimensions**

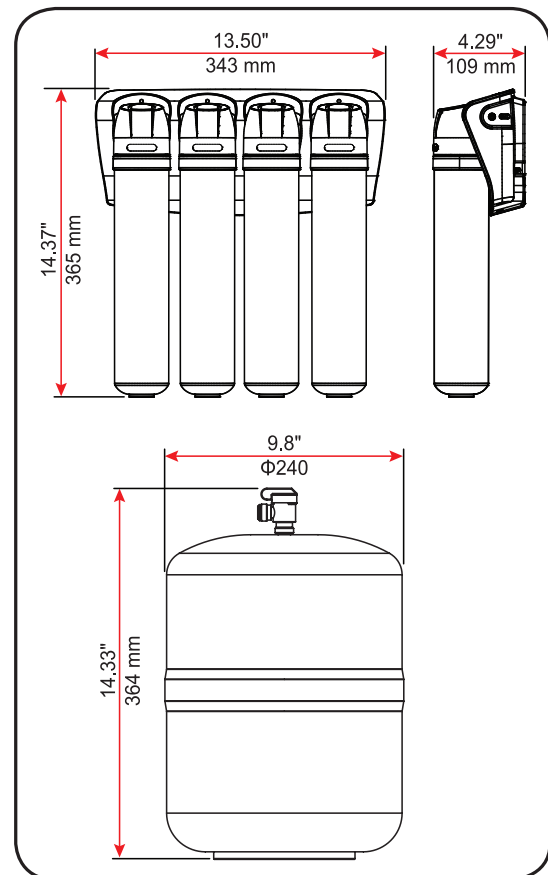

\* Please call your dealer for replacement filters.

RECOMMENDED FEED WATER CHARACTERISTICS		STAGE
Working Pressure	30 - 125 psi (207 - 862 kPa)	1. The reverse osmosis membrane used in these systems may be damaged by chlorine. These systems include activated carbon filters which protect the membranes by reducing chlorine. Influent chlorine should not exceed 3 mg/L
Temperature	39 - 100 °F (4 - 38 °C)	
pH range	5 - 10	
Turbidity	< 1.0 Net Turbidity (NTU)	
Hardness (CaCO3)	< 300 ppm	2. Additional information on factors that affect RO performance can be found in the "Performance & Technical Information" section.
Iron (Fe)	0 - 1 ppm	
Chlorine (Cl2)	0 - 3 ppm (0-3 mg/l)	

## Installation Instructions

### TYPICAL INSTALLATION DIAGRAM

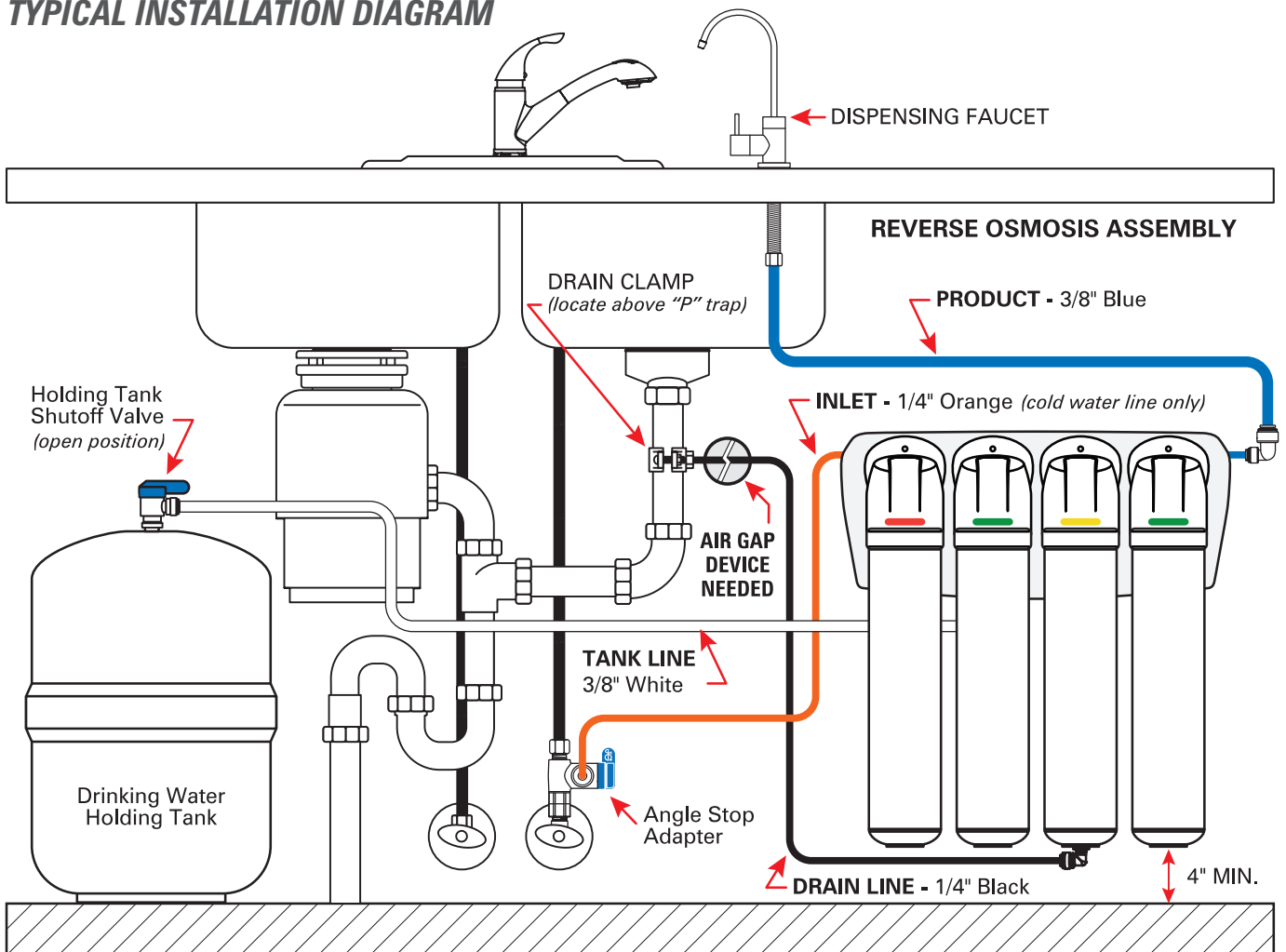

## **Step 1 – Select Component Installation Locations**

### **• Dispensing Faucet**

- The faucet is designed to be mounted on the rear lip of the sink. It may be installed in an existing sprayer attachment hole or in a hole drilled at the time of installation. It may also be mounted to an adjacent counter top. It should be positioned so that water is dispensed over the sink. A 7/8" diameter hole is required.
- In restricted under-sink areas, it may be easier to install the faucet first. Allow adequate tubing lengths for any final component position.

### **• Important Considerations**

- Access to the bottom (under sink) of the faucet is required for attachment of product water line.
- There should be no under sink obstructions which would prevent smooth tubing runs to the drain connection, or RO module assembly.

### **• Reverse Osmosis System Assembly**

- The RO system assembly is designed to be mounted on any rigid vertical surface such as a cabinet sidewall, sheet rock, or exposed stud. It should be positioned such that there is access to an inlet water source and drain. The installation should also allow convenient access for servicing. The parts bag has 2 self tapping screws. Using a Phillips screwdriver, screw them into the cabinet wall using the template provided as a guide.

### **• Inlet Water Supply Connection**

- Once a location is chosen for installation of the RO system assembly, select a nearby COLD water line to provide the water source for the system.



**NOTE:** Follow all local plumbing codes when connecting to service water.

### **• Drain Connection**

- The most convenient entry to the drain is directly above the P-trap of the kitchen sink. However, the drain water from the system can be connected to adjacent sinks or a floor drain. Extra care should be taken when entering drains near dishwashers or food waste disposals as back-flow may occur through the air gap and cause flooding.
- Plumbing codes require back-flow prevention. An air gap fitting (sold separately) should be mounted in the drain line (waste line) of Reverse Osmosis System and the primary purpose is to prevent non-potable water from flowing backwards possibly mixing and contaminating potable (drinking) water. One could think of the function of an air gap fitting as a no-fail check valve but without an internal seat or any moving parts. Properly designed and installed, air gaps, like check valves, allow water to flow only in the desired direction.



**NOTE:** Follow all local plumbing codes when connecting to drain. Some codes may require installation by a licensed plumber; check with the local plumbing authority prior to installation.

## **Quick-Connect Tubing Connector Fittings**

The Quick Change Twist & Loc RO Water Filtration System features reliable and convenient push-to-connect tubing connectors. Tubing is easily connected and disconnected from these fittings as follows.

### ***Connect:***

Cut the tubing squarely with a sharp knife. Be careful not to crush the tubing. To avoid leaks, make sure the tubing end is smooth and free of burrs and abrasions. Lubricate the end of the tube with water or a light coat of silicone and push the tube end firmly into the fitting. You should feel it push past the O-ring. Avoid bending the tubing sharply away from the fitting.

### ***Disconnect:***

Hold the collar against the fitting body and pull the tube from the fitting. In the unlikely event that the connection leaks, remove and recut the tubing. Check the inside of the fitting for debris or O-ring damage. Reconnect. Push-to-connect tubing connectors grip the outside diameter of the tube. To help assure a reliable connection, it is important to use high quality tubing with a consistent outside diameter.

Should a leak occur at a fitting, the cause is usually defective tubing.

To fix:

- Relieve pressure
- Release tubing
- Cut off at least 1/4" from end
- Reattach tubing
- Confirm connection is leak free

### ***To Attach Tubing***

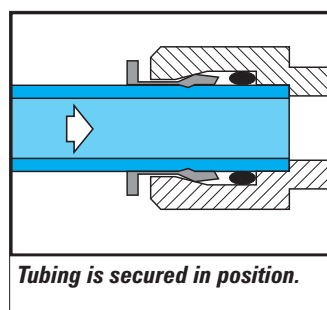
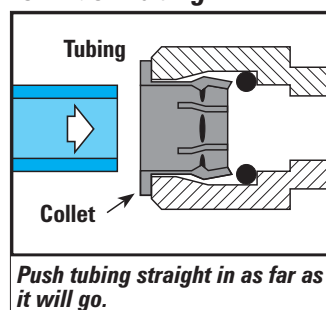

### ***To Release Tubing***

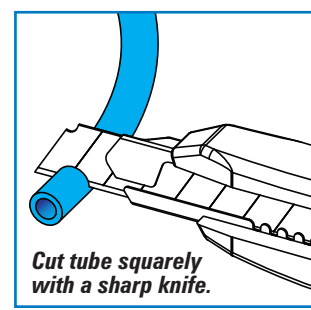
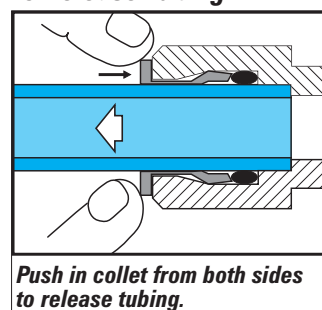

## **Step 2. Faucet Installation**

To simplify its access and installation, we suggest you install the faucet on the rear lip of the sink (as shown in the stainless steel sink drilling instructions). It should be evenly positioned with the sink faucet and spray attachment. Should the spray faucet hole not be available for the installation, the sink must be drilled.

The parts bag has a 3/8" tubing adapter with a short piece of blue 1/4" tubing. Install in the 1/4" Out Connection on the right side of the RO system, as shown to the right.

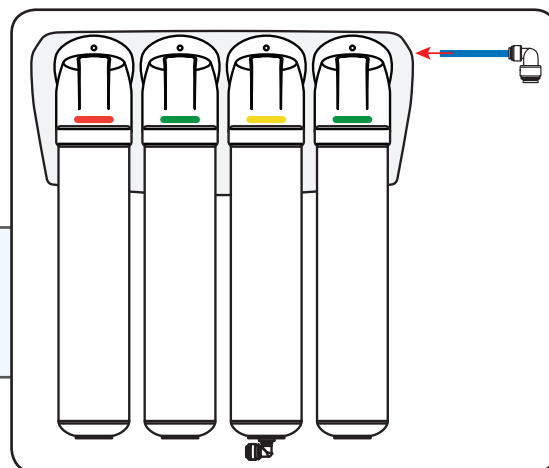

**NOTE:** It is recommended retaining the services of a professional counter-top craft person when a hole is needed in granite or other specialty counter-top materials.



## Sink Drilling Instructions

### Stainless Steel Sink

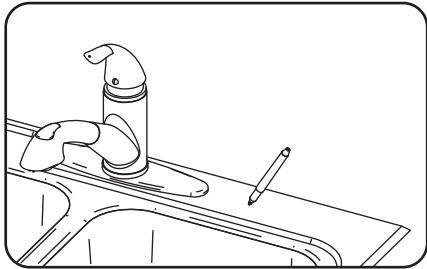

1. Select and mark the proper faucet location.

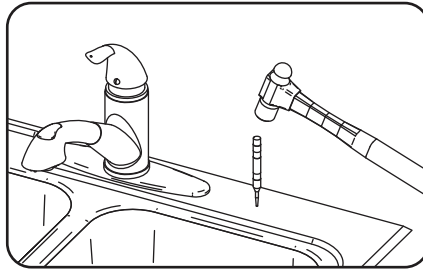

2. Center punch hole to provide a starting point for your drill.

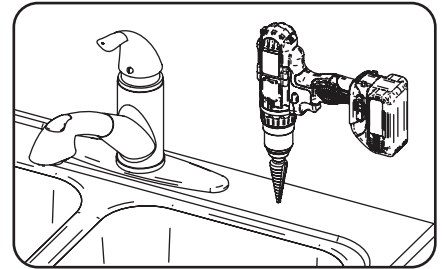

3. Drill a 7/8" hole in the sink using a stepped 7/8" drill bit. If no stepped bit is available, start by drilling a 1/4" hole. Using this hole as a starting point, progressively drill larger holes. Increase drill size by 1/8" until you reach a 7/8" hole.

### Porcelain Enamel Sink

Follow these basic guidelines when drilling a porcelain sink:

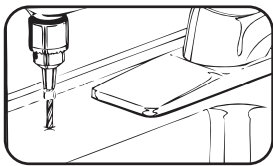

- Pilot Drill

- Penetrate the porcelain to the base material.

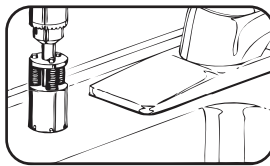

- Spring Loaded Porcelain Saw

- Protect the surrounding porcelain material.

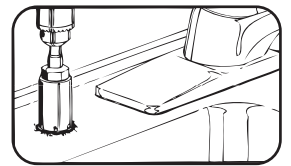
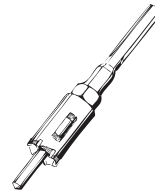

- Finish Hole Saw

- Use the appropriate tool to drill the base material.

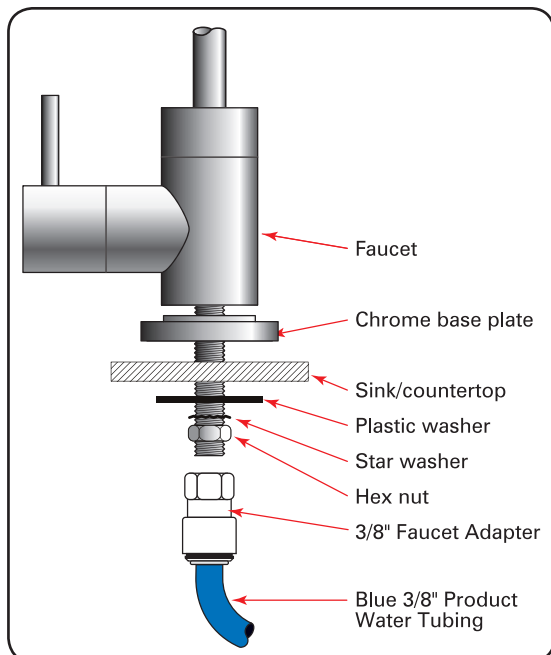

Take length of 3/8" blue tube and make sure it has a fresh cut and is free of foreign materials and any scratches on the outside surface. Install the tubing into the push in type fitting at the base of the faucet. Make certain that it is inserted all the way in; once inserted give it a slight pull to make sure it is locked into the fitting.

You have now completed the tubing connections.



#### NOTE:

To disconnect tubing from the product water fitting, hold the collet firmly against fitting body and pull the tube from the fitting. Repeated assembly and disassembly will cause wear to the inner body. Visually inspect for excessive wear and replace the inner body as needed to protect against any leaks.

### Step 3 – Install Adapter Valve on Water Supply



**CAUTION!** The Adapter valve should be connected to cold water supply only. Connection to hot water supply will damage the system and will void all warranty.

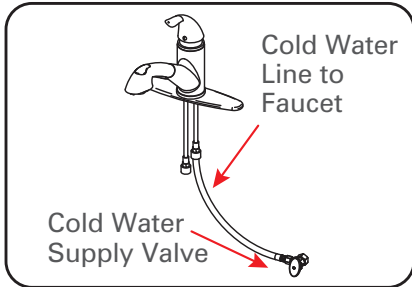

1. Shut off water at supply valve.

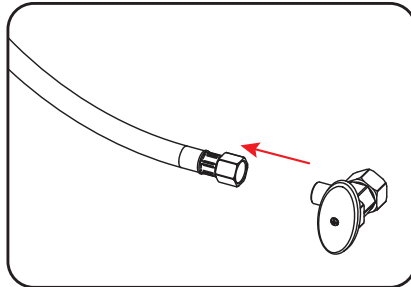

2. Disconnect hose from supply valve.

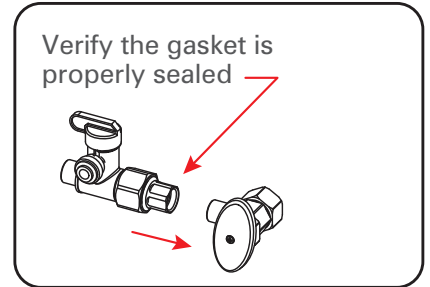

3. Install adapter valve on supply valve.

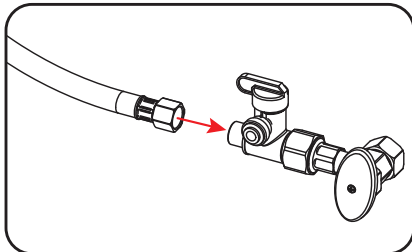

4. Connect riser hose to adapter valve.

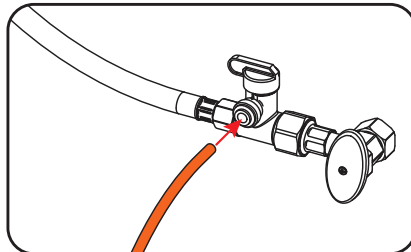

5. Insert 1/4" orange tube into quick connect fitting on valve.

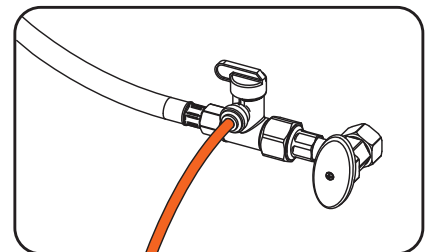

6. Open the cold water supply valve and check for leaks.

### Step 4 – Connect System Drain

This connection can usually be made beneath the sink. Incorrect installation may result in overflow of the air-gap or excessive noise. Connections to under sink plumbing can be made with a saddle clamp designed to accept the drain tubing from the faucet. Drain Saddle Kit is supplied for 1-1/2" under sink drain plumbing. Be sure to check and follow local plumbing codes prior to installation.

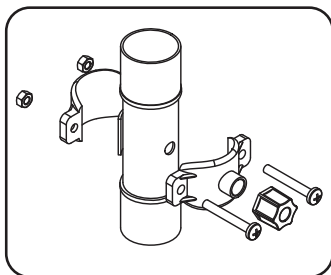

1. Install the drain saddle valve on to the drain pipe. Use 1/4" saddle for drain water line.

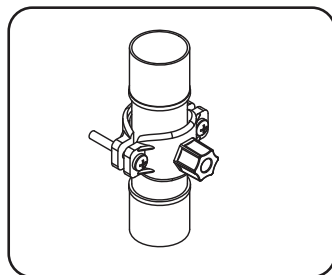

2. Tighten the clamps with the help of the two bolts.

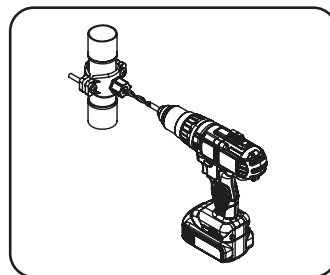

3. For the standard faucets drill a 1/4" hole through one side of the pipe. The drill should be kept straight and centered to avoid damaging the saddle valve. Do not drill through both sides of the pipe!

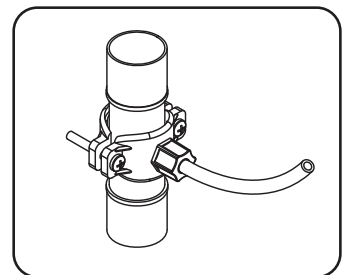

4. Attach 1/4" black tube by slipping the tube through the black compression nut and hand tighten the nut on to the saddle valve.



**CAUTION!** Do not over tighten.



**CAUTION!** Do not drill through both sides of pipe!



**CAUTION!** The drill should be kept straight and centered to avoid damaging the saddle valve.

Many homes are equipped with disposals and dishwashers. Home drain plumbing must be free of any blockage since this may cause a backup of dishwasher and disposal waste into the drain line and result in improper performance. To perform a simple drain check, fill the sink basin with several inches of water, pull the plug, and observe the drainage. If water backs up into the second sink (if present), or if drainage is slow or there is excessive gurgling, drain blockage may be present. Under sink drain plumbing usually resembles one of the following descriptions. In all cases, the drain tubing from RO membrane filter should run downward, free of dips and loops. This can vent sewer gas, which will produce foul odors.

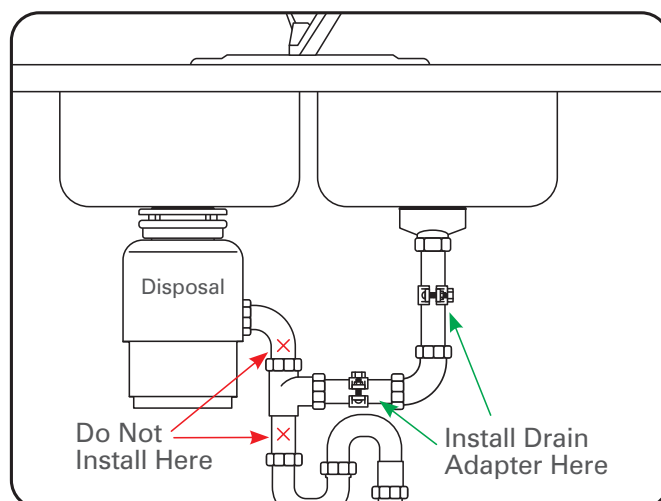

### **Step 5 – Tank Sanitizing & Installation**

The tank should be sanitized. It is important to use a sanitizer in the tank so the solution can sanitize the tubing, fittings, and faucet at the time of installation and startup.

- Put 1/2 tsp. or 3 ml of a good quality unscented 5-1/4% liquid bleach directly into the tank. Handle bleach according to manufacturer's instructions.
- Wrap the threads on the top of the water storage tank 3 times with plumbers (Teflon) tape only.
- Connect the tank ball valve (supplied in the parts bag) to the top of the water storage tank. Make sure it is tight, but not over tight.

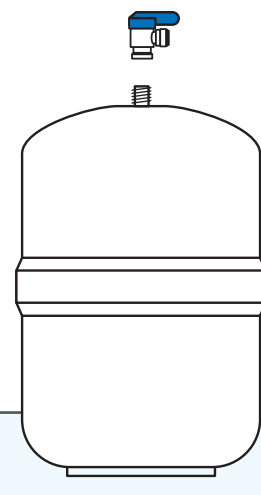

**NOTE:** Do not tamper with the air valve on the storage tank. It has been preset and screwed on with blue cap by the manufacturers.

### **Step 6 – Start-Up**

- 1 Sanitize the storage tank.
- 2 Check system to verify all components are correctly installed.
- 3 Open inlet valve and tank valve.
- 4 Check system thoroughly for leaks. If any are found, shut off both inlet and tank valves and correct the issue.
- 5 Allow system to run & fill tank for 1-2 hours. You will hear the water running to drain while the unit is running. Once the water stops running to drain the tank is full.
- 6 Open faucet and allow tank to drain completely to flush carbon fines & sanitizing solution. **Do Not Use This Water.** Once the flow begins to slow down (around 20 minutes after opening) turn off the faucet.
- 7 Allow the tank to fill completely again.
- 8 Once full, open the faucet and allow the water to run for 24 hours to break-in the RO membrane and completely flush the system. **Again, Do Not Use This Water.** This will allow your system to run at optimal efficiency.
- 9 Close faucet and allow tank to fill.
- 10 System is ready to use.

## Sediment & Carbon Cartridge Replacement

1. Pull bottom of Cartridge out to a 45° angle.
2. With one hand, rotate the old filter cartridge counter clockwise to remove the filter.
3. Discard or recycle the used cartridge. Line up the bayonets (tabs) of the new cartridge in the slots, insert and twist 1/4 turn clockwise until tight to lock the filter cartridge. Place cartridge in vertical position.
4. Repeat previous steps on the next filter.
5. Turn on the water supply and check for leaks.
6. After replacing all cartridge filter cartridge stages, flush system with one tankful of water before use.
7. Replace filter cartridge regularly to ensure the quality of drinking water and extend the life of the system.

### Recommended Filter Change Schedule\*

Stage 1 - Sediment Cartridge	6 Months
Stage 2 - Carbon Cartridge	6 Months
Stage 3 - RO Membrane	24 Months
Stage 4 - Carbon Cartridge	6 Months

\*Based on standard conditions.



**NOTE:** The need for filter replacement varies with water quality and usage. Replace cartridges on a regular basis to ensure the highest quality water and extend the life of the system.

## RO Membrane Cartridge Replacement

1. To replace the RO membrane, twist the membrane counter clockwise 1/4 turn to unseat the membrane. A little water may drip from the top of the membrane/cartridge seal.
2. Compress the fitting collet at the bottom of the membrane to release the drain tubing fitting and remove the drain tubing fitting from the housing, (as shown to the right).
3. Install the drain tubing and seat it properly into the new membrane cartridge.
4. Install the new membrane into the RO bracket by twisting clockwise. Check the top of the membrane for leaks and re-seat if necessary.
5. Check the drain tubing to make sure it is securely and correctly installed and not leaking.
6. Follow the start up procedures to purge the membrane preservative from the system. See page 9 of the instructions.



# Performance & Technical Information

The performance of the RO System can be characterized and judged by the quality and quantity of the water produced by the system. By measuring the contaminant removal performance and flow rates of the system, its operating status can be easily evaluated.

## **FACTORS WHICH AFFECT PERFORMANCE**

Performance of the reverse osmosis membrane is affected by several factors which must be considered when judging the condition of the system. The main factors which affect system performance are pressure, temperature, total dissolved solids level, recovery and pH.

### **PRESSURE**

Water pressure affects both the quantity and quality of the water produced by the RO membrane. Generally, the more water pressure, the better the performance of the system. Pressure Regulator is recommended for feed water pressure exceeding 80 psi.

### **TEMPERATURE**

The reverse osmosis process slows with decreasing temperature. To compensate, a temperature correction factor is used to adjust the actual performance of the RO membrane filter to the standard temperature of 77°F(25°C). This allows the performance of the unit to be accurately gauged against published standards. Temperature does not affect the concentrate flow rate.

### **TOTAL DISSOLVED SOLIDS**

The minimum driving force which is necessary to stop or reverse the natural osmosis process is termed osmotic pressure. As the total dissolved solids level of the feed water increases, the amount of osmotic pressure increases and acts as back pressure against the reverse osmosis process. Osmotic pressure becomes significant at TDS levels above 500 mg/L (ppm).

### **HARDNESS**

Hardness is the most common cause of membrane fouling. If ignored, this relatively harmless component of feed water will scale a membrane over time. Use of a softener will reduce the fouling effect on a membrane. One way to detect too much hardness in the feed water is the weight of a membrane installed for a period of time. A fouled membrane (dried) will weigh significantly more than a new membrane. The increase in weight is a result of precipitated hardness inside the membrane.



**NOTE:** Increased weight of the RO cartridge may be a fouling other than hardness.

# Troubleshooting Guide

If a problem cannot be corrected through the use of this troubleshooting guide, please call your installing dealer.

PROBLEM	POSSIBLE CAUSE	REMEDY
1. Insufficient quantity of product water available to service	A-Service greater than unit's specified output	a-Use optional large tank for more storage capacity
	B-Insufficient feed water flow	b1-Clogged shut-off valve for feed tubing; Cleanout or replace b2-Clogged prefilter; Replace b3-Clogged manifold; Clean or Replace
	C-Insufficient feed water pressure	c1-Same as (b) above c2-Change in line pressure; Install booster pump
	D-Increase in feed water TDS.	d1-Same as (a) above d2-Install booster pump
	E-Reduced feed water temperature	e-Same as above
	F-Plugged pre-filter	f-Replace filter element
	G-Plugged polishing filter	g-Replace polishing filter
	H-RO membrane fouled with sediment	h-Replace RO membrane & pre-filter elements
	I-Shutoff malfunction	i-Clean or replace shutoff
2. Poor product water quality	A-All of (1) above except (a) and (e)	a-All of (1) above except (a), (e), and (g)
	B-RO membrane filter worn out	b-Replace RO membrane
	C-Shut off malfunction	c-Replace shut off
3. Bad tasting product water	A-Decrease in product quality; see (2) above	a-Same as (2) above
	B-Foreign matter in storage tank	b-Clean, sanitize, and flush storage tank
	C-Polishing filter exhausted	c-Replace polishing filter
	D-Storage tank bladder is ruptured	d-Replace storage tank and check pre-charge pressure
4. External leakage	A-Tubing not fully seated in fitting	a-Check all fittings for tightness
	B-Tubing abraded in seal area	b-Recut tubing and redo connection
5. If an Air Gap Faucet is installed, overflow at faucet air gap (gurgling sounds)	A-Concentrate tubing plugged	a-Clean concentrate tubing of debris
	B-Concentrate tubing not in continuous downward slope	b-Eliminate loops or low spots in tubing
	C-Obstructed home drain pipe	c-Free obstruction
6. Foaming at faucet tip	A-Storage tank is positioned on side (Dissolved air cannot escape.)	a-Place tank in vertical position
7. Foaming at air-gap	A-Concentrate tubing connected to same drain line as dishwasher, etc.	a-Find different drain for system
	B-When sink is full of soapy water and plug is pulled, can back up at air-gap	b-Obstructed home drain, free obstruction
	C-Obstructed home drain	c-Free obstruction

PROBLEM	POSSIBLE CAUSE	REMEDY
8. Bad smell from product water	A-Polishing filter exhausted	a-Replace polishing filter
	B-Pre-filter element	b-Replace filter element
	C-Unit needs disinfection	c-Sanitize unit
9. Fast flow to drain	A-Defective flow control assembly	a-Replace flow control assembly
10. Black specks in product water	A-Carbon fines	a-Flush polishing filter
11. Low faucet pressure	A-Inadequate pre-charge pressure in storage tank	a-Check tank pre-charge pressure and add air if required
	B-Polishing filter plugged	b-Replace polishing filter
12. Flow control plugging	A-Excessive turbidity	a-Install another 5 micron filter in series with existing one or substitute carbon block filter for granular activated carbon filter
	B-Iron fouled	b-Pre-treat for iron removal
	C-Iron-bacteria fouled	c-Sanitize plumbing

## Limited One-Year Warranty

### LIMITED ONE-YEAR WARRANTY

The system is warranted for defects in material and workmanship only for one year from date of purchase and with proper adequate maintenance. Product compatibility and application suitability are the sole responsibility of the user. Installation must be conducted in accordance with supplier's express written recommendations, complying with recognized codes of practice and relevant national standards, and all systems must be properly maintained. The manufacturer's warranty covers systems for water use only and water pressure regulated area only, unless otherwise specified in writing. Leaks and other malfunctions resulting from improper installation or inadequate maintenance are not covered by the warranty, and insurance liability coverage is the responsibility of the user.

The warranty does not cover the following:

- Improper installation, delivery or maintenance.
- This warranty shall not apply to any failures damaged by abuse, misuse, alteration, or failure to follow operating condition/notices and installation instructions.
- Use of this product where water is microbiologically unsafe or of unknown quality, without adequate disinfection before or after the system.
- Damage to the product caused by accident, fire, floods or acts of God.
- Incidental or consequential damage caused by possible defects with this application, it's installation or repair.

### EXCLUSION OF IMPLIED WARRANTIES

Your sole and exclusive remedy is product exchange as provided in this Limited Warranty. Any implied warranties, including the implied warranties, including the implied warranties of merchantability or fitness for a particular purpose, are limited to one year or the shortest period allowed by law.

Manufactured for Nelsen Corporation by MICROFILTER Co., Ltd.

# Reverse Osmosis System OWNERS MANUAL



*Quick Change, Twist & Loc*