

NELSENTM

WATER SOLUTIONS

Aqua Series

Reverse Osmosis

Reverse Osmosis Drinking Water Systems

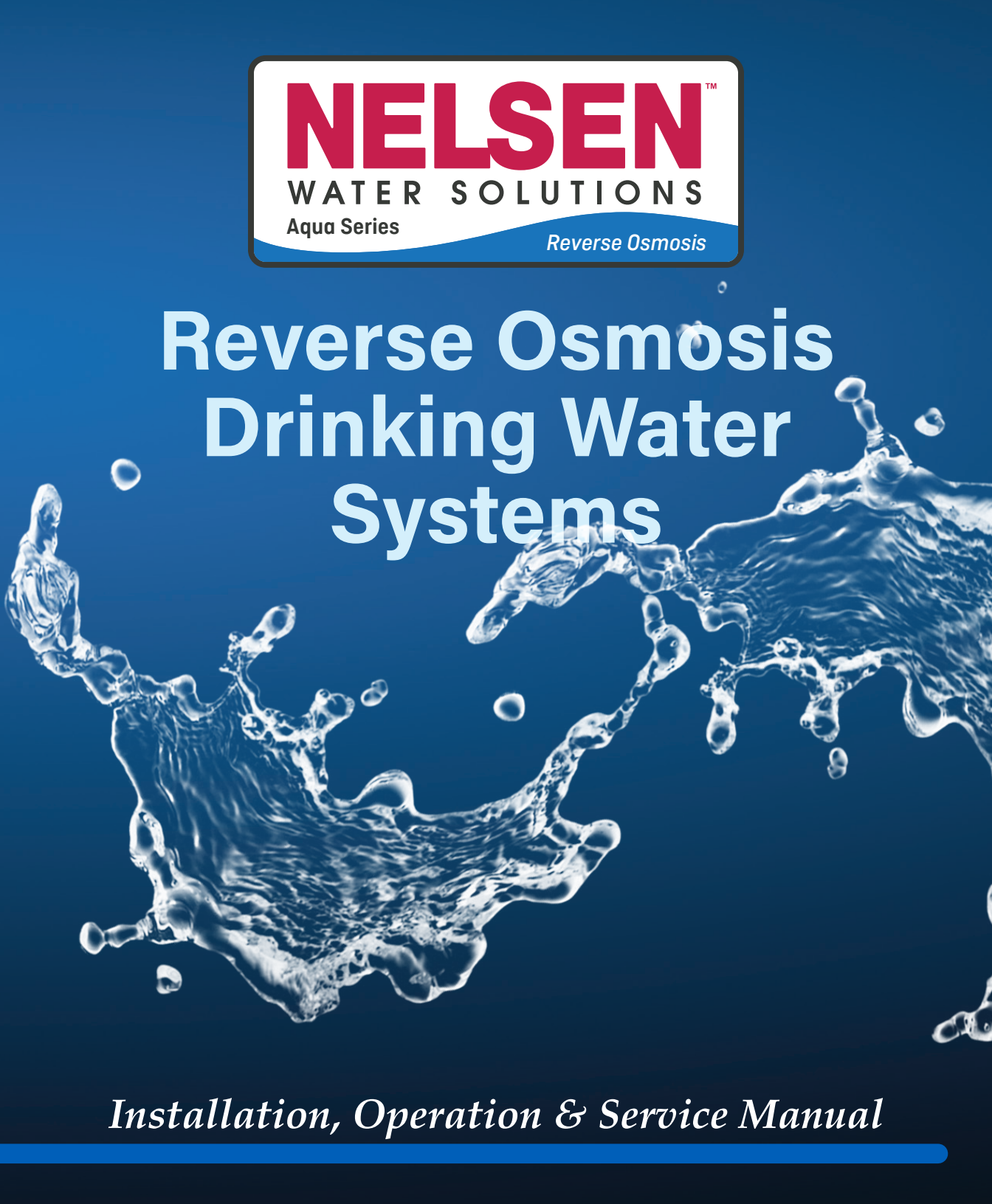

Installation, Operation & Service Manual



RO Model Identification.....	2
System Recommended Operating Limits For Feed Water.....	2
Section I - Introduction.....	3
Recommended Filter Change.....	3
Section II - Installation Diagrams.....	4 - 5
Section III - Preparation.....	6 - 7
Major Systems Components.....	6
Section IV - Installation Steps.....	8 - 9
Faucet Installation.....	8
Feed Valve Installation.....	10
Sanitizing the Storage Tank and System.....	11
Drain Clamp Installation.....	11
Making the Tubing Connections.....	12
System Start-Up.....	13
Section V - Basement Installations.....	14
Section VI - Operation & Maintenance.....	14 - 15
Section VII - Technical Data.....	16
Section VIII - Booster Pump Models - Installation.....	18
How to Use Quick Connect Fittings.....	20
Reverse Osmosis Process.....	20
Warranty.....	21
Figure 1 - Aqua Classic & Elite Installation Diagram.....	4
Figure 1a - Aqua Premier Installation Diagram.....	5
Figure 2 - Faucet Installation Diagram.....	8
Figure 3 - Angle Stop Adapter Service Position.....	9
Figure 4 - Angle Stop Adapter Installation Diagram.....	9
Figure 5 - Feed Valve Installation Diagram.....	9
Figure 6 - Drain Clamp Installation Diagram.....	11
Figure 7 - Booster Pump Model Installation Diagram.....	17
Figure 8 - General Basement Installation Diagram.....	19

RO Model Identification



Aqua Classic Series



Aqua Classic Series
3-Stage



Aqua Classic II Series
4-Stage



Aqua Classic Booster
Pump Series
3-Stage



Extended Contact
Carbon Filter
*Added to any of the
previous models shown.*



Aqua Elite Series



Aqua Elite Series
3-Stage



Aqua Elite II Series
4-Stage



Aqua Elite Booster
Pump Series
3-Stage



Extended Contact
Carbon Filter
*Added to any of the
previous models shown.*



Aqua Premier Series



Aqua Premier Series
5-Stage



In-line Alkaline Filter
*Added to the previous
model shown.*

System Recommended Operating Limits for Feed Water

Feed Water T.D.S.	2000 ppm max
Feed Water Temperature	40 - 110° F
Feed Water pH	5 - 10
Feed Water Pressure	40 - 85 P.S.I.
Feed Water Hardness	Less Than 10 Grains Per Gallon
Feed Water Iron	Less than 0.1 ppm
Feed Water Manganese	Less than 0.05 ppm
Feed Water Hydrogen Sulfide	NONE
Feed Water Supply	No Chlorine
Feed Water Bacteria	Must Be Potable

SECTION I. Introduction

Congratulations, you have just purchased one of the finest Reverse Osmosis Drinking Water Systems available. The Aqua Series of Reverse Osmosis Systems have a combined engineering and experience level of over 50 years behind them. They were designed with a minimum of service and will serve you for years to come.

Like any other fine product, this appliance requires periodic maintenance in accordance with the schedule outlined below.

Recommended Filter Change Schedule*

1) Pre-filter, 10", 5 Micron.....	6 Months
2) Granulated Activated Carbon Pre-filter and/or Post-Filter.....	6 Months
3) Reverse Osmosis Membrane.....	24 - 36 Months
4) Post Granulated Activated Carbon Filter.....	6 Months
5) Extended Contact Carbon Adsorption Filter (ECF Module - Optional).....	6 Months

**Based on standard conditions.*

Your new Reverse Osmosis (RO) Drinking Water System uses a combination of filtration technologies to reduce unwanted contaminants in a water supply. The following steps combine to give you the best in clear sparkling drinking water:

MECHANICAL FILTRATION - The sediment pre-filter will remove the larger particles such as silt, rust and scale. Its 5 micron (equal to 0.0002 inch) nominal rating helps to give maximum life to the RO Membrane and carbon filter.

CARBON BLOCK PRE-FILTER -

Found on the Aqua Classic II, Aqua Elite II, and Aqua Premier (3-filter housing) RO Systems - The carbon block pre-filter will remove any chlorine that may be present in the feed water. This pre-treatment is also necessary for membrane protection.

REVERSE OSMOSIS MEMBRANE - The RO Membrane is the heart of the filtration system. It is designed to reduce the dissolved mineral content of the water. Minerals picked up in the environment by the water are measured as Total Dissolved Solids (T.D.S.). In the Reverse Osmosis process, dissolved minerals are separated from the incoming water (Feed Water) to produce the product water (the Permeate). The excess minerals are rinsed to drain (the Reject Water).

The spiral wound construction of the RO Membrane provides maximum surface area for water production and is less susceptible to fouling by particulate matter, turbidity and colloidal materials.

TFC Membranes - Thin Film Composite (T.F.C.) Membranes are specially constructed, fully aromatic polyamide film and are classified as a thin film composite. These membranes are NOT chlorine resistant.

CARBON BLOCK POST-FILTER (Classic & Elite)

ACTIVATED CARBON POST IN-LINE FILTER (Premier)

- The Carbon Block Post-filter cartridge contains a vast network of pores for high adsorptive properties. The coconut shell activated carbon block simultaneously remove chloramines, free chlorine and organic chemicals that contribute to taste and odor.
- The In-Line Post-filter, Granular Activated Carbon, (GAC) filter contains coconut shell carbon to reduce unpleasant taste and odor from drinking water.

The product water from the membrane as well as the holding tank passes through the post-filter on the way to the Dispensing Faucet. The post-filter reduces tastes and odors that may pass through the system. It adds a final "polish" to the water.

EXTENDED CONTACT CARBON ADSORPTION

FILTER (ECF Module - Optional) - This slow flow carbon filter is designed to reduce certain organic compounds and chloramines.

IN-LINE ALKALINE FILTER (Optional) - This filter increases the pH level to change acidic RO water into a perfect natural alkali calcium ionized water by adding back into the water essential and beneficial elements such as ionized calcium, magnesium, sodium and potassium.

AUTOMATIC SHUT-OFF VALVE - The A.S.O. Valve senses when the product water tank is full and closes the feed water supply to prevent excess reject water from going to drain when the unit is not producing water.

SECTION II. Installation Diagram - Aqua Classic & Elite

FIGURE 1 Installation Diagram

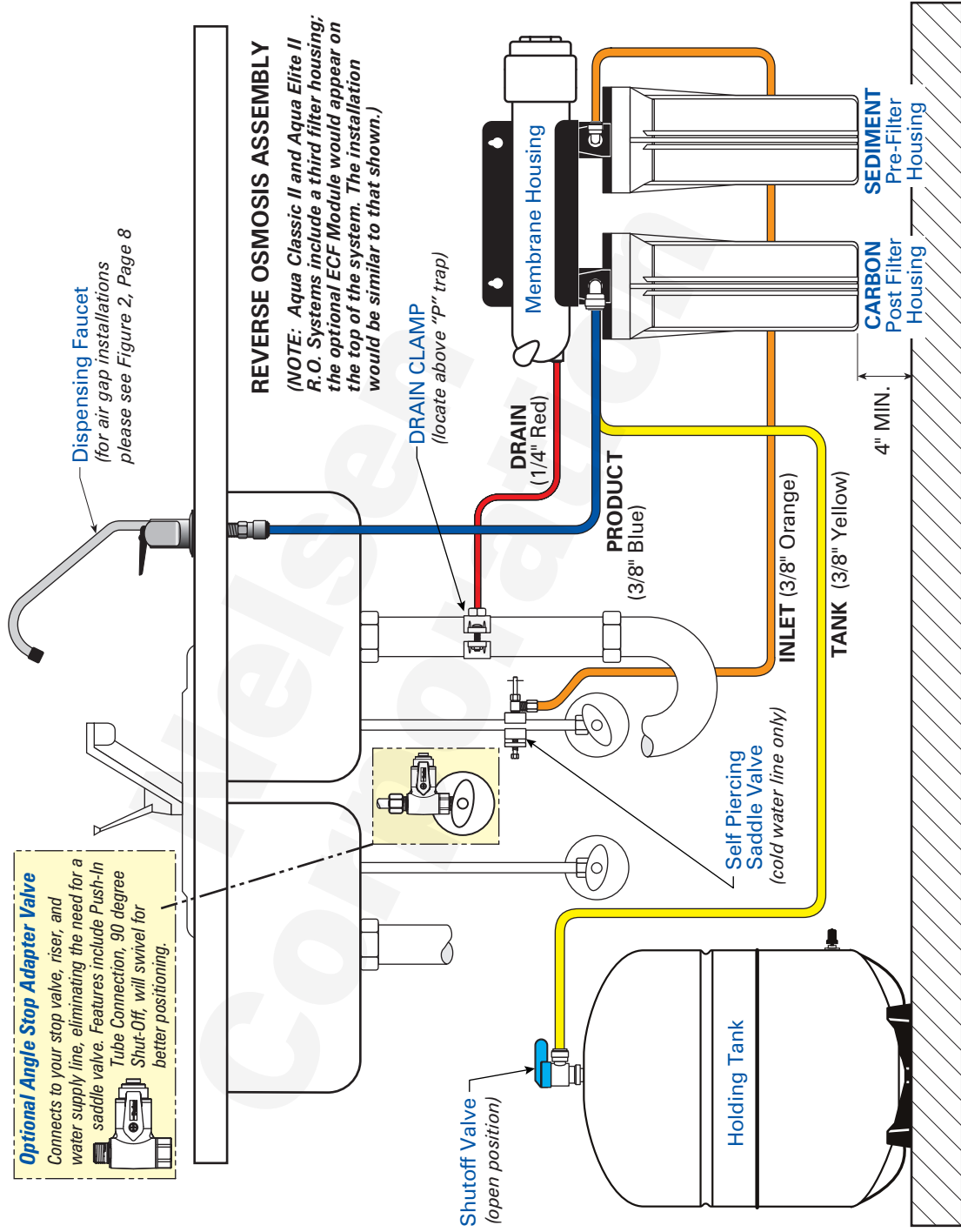

SECTION II. Installation Diagram - Aqua Premier

FIGURE 1a Installation Diagram

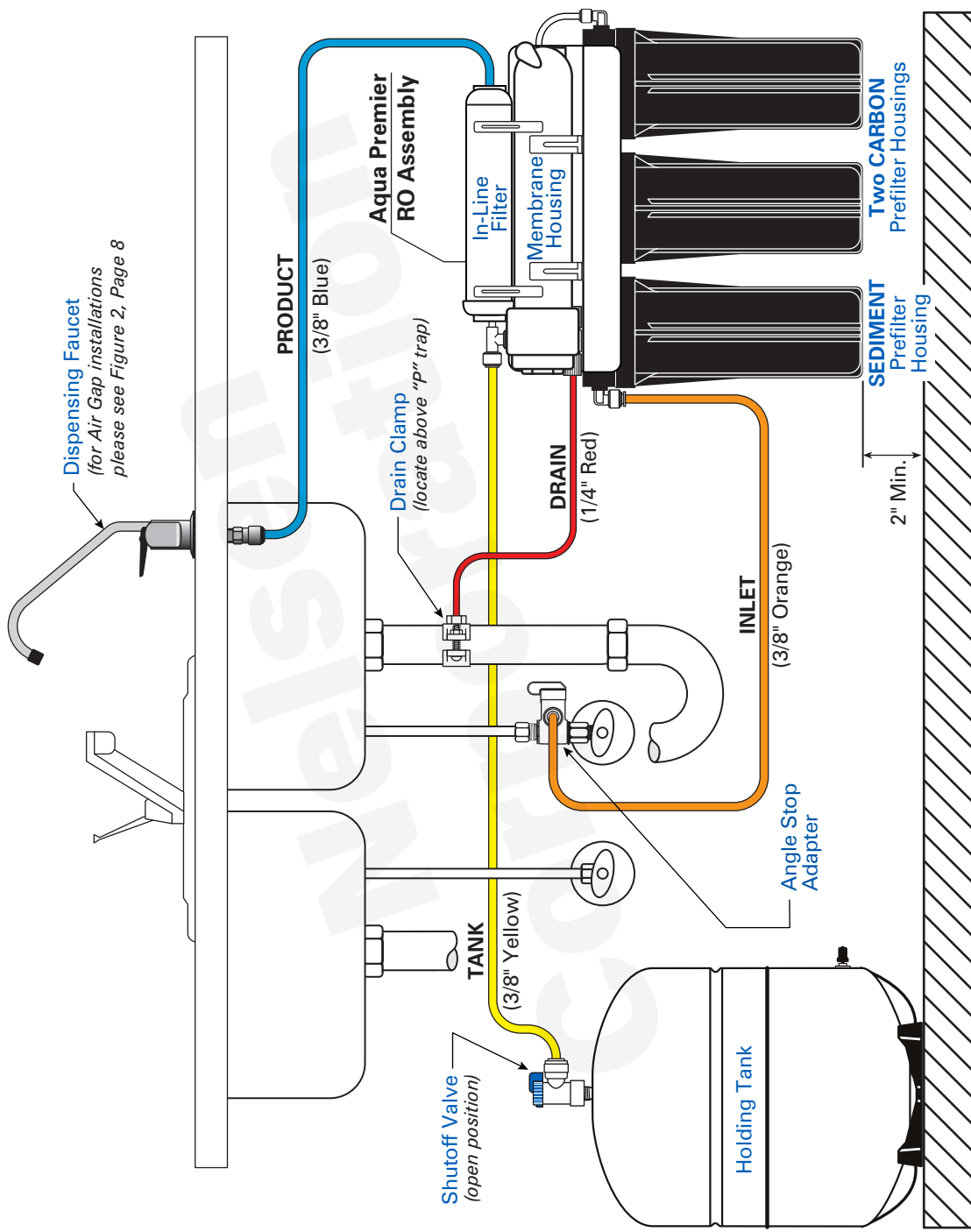

SECTION III: Preparation

A. Major System Components

The following components comprise the RO Drinking Water System (Refer to Figures 1 and 1a on pages 4 & 5 for general system layout.)

- 1) A RO assembly consisting of the mounting bracket, filter housings, automatic shut-off and membrane module
- 2) A Drinking Water Holding Tank
- 3) Faucet optional with Aqua Premier
- 4) A plastic tubing kit with a feed water valve and drain clamp
- 5) Other items necessary for installation not included, may include concrete anchors for hanging on basement wall, additional tubing or tube connectors, plastic wire ties for organizing tubing

Optional Components

- 1) ECF Module - Extended Contact Carbon Adsorption Filter located on the RO Assembly
- 2) In-line Alkaline Filter - This filter increases the pH level to change acidic RO water into a perfect natural alkali calcium ionized water by adding back into the water essential and beneficial elements such as ionized calcium, magnesium, sodium and potassium.
- 3) A T.D.S. Monitor with feed water and product water test cells

* The T.D.S. Monitor may be necessary to conform to state or local codes, check with the local plumbing authority.

B. Tools Recommended for Installation

The following tools will cover most of the installation sites encountered:

- 1) 3/8" variable speed electric drill
- 2) Extension work light with outlet
- 3) Safety Glasses
- 4) 1-1/4" porcelain hole cutter kit
- 5) 1-1/4" Greenlee hole punch and 1/8" and 1/2" metal drill bits for pilot hole
- 6) Center punch and hammer
- 7) 1-1/4" wood bit
- 8) Concrete drill bits
- 9) Assorted wood and metal drill bits including 7/32" metal drill bit

- 10) Phillips head and flat blade screwdrivers
- 11) 1/2", 9/16" and 5/8" open end wrench
- 12) 10" Crescent wrench with jaws taped to hold faucet
- 13) Basin wrench or 10" pipe wrench
- 14) Teflon tape
- 15) Wide masking tape or duct tape
- 16) Plastic tubing cutter
- 17) Extra plastic tubing
- 18) Low range air pressure gauge
- 19) Bicycle hand air pump
- 20) Graduated measuring cylinder
- 21) Assorted clean up materials
- 22) A good quality sanitizer, ie. Sani System from Pro-Products

C. Determine System Location

The system can be located under a sink or in a basement depending on space availability and the customer's preference. If a basement installation is selected, additional tubing, hardware and fittings may be needed and a hole will have to be made from inside the cabinet, through the floor, to the basement. Never install in an area of the home where temperature is freezing as damage to the system will result.

The exact placement of the various components of the system will vary from installation to installation. The installer, in conjunction with the customer, must decide on where to place the faucet, tank and purification assembly by balancing the homeowner's convenience with ease of installation and servicing.

NOTE

Considerations for an ice maker or other remote hookup should be determined, including routing and any additional tools, fittings, and tubing that may be required.

- 1) **Faucet** - The faucet should be placed near the sink where drinking water is normally obtained. Convenience of use (filling of water pitchers and glasses), and an open area beneath the faucet under the sink for attaching product and drain tubing (air gap faucets only) are considerations. A 2" diameter flat surface is required above and below the mounting site. The thickness of the mounting surface should not exceed 1-1/4". Watch for strengthening webbing on the underside of cast iron sinks.

- 2) **Drinking Water Holding Tank** - The holding tank may be placed where it is convenient within 10 feet of the faucet, under the sink or in an adjacent cabinet are best choices. If a longer run of tubing is required, the tubing should be the 1/2" diameter O.D. size to prevent a high pressure drop. Remember, these tanks can weigh up to 30 pounds when full of water, a firm, level area is required.
- 3) **R.O Assembly** - The RO Assembly may be mounted on either the right or left side of the under-sink area or a cabinet. Mounting in the basement is also an option, one possible location is near the laundry/utility sink where cold potable water and drain access is handy. The mounting location should allow adequate clearance and accessibility for cartridge changes.
- 4) **Feed Water Connection** - The feed water shut off valve should be located as close to the RO assembly as possible. USE A POTABLE COLD WATER SUPPLY ONLY. Softened water is preferred as it will extend the life of the RO Membrane.
- 5) **Drain Connection** - The drain saddle assembly is designed to fit around a standard 1-1/2" OD drain pipe. The drain saddle should always be installed above (before) the trap and on the vertical or horizontal tail-piece. Never install the drain saddle close to the outlet of a garbage disposal or plugging of the RO drain line may occur. If discharging into an utility sink or standpipe, an air gap of greater than 1" above the flood rim must be provided. Do NOT connect the system drain line to the dishwasher drain or near the garbage disposal. Back pressure from these units may cause the air gap to overflow.

D. Prepare the Area for Installation

If a basement installation, determine where components will be located and how they will be mounted. Special mounting brackets and hardware may be necessary to secure the system to a wall or ceiling joists.

Inspect cold water supply line and drain to determine if any special fittings, in addition to what is included in the kit, are required.

E. Prepare the System for Installation

Open shipping carton and remove components. Check that all installation parts are present which includes the purification assembly, storage tank, faucet (not included with Aqua Premier), installation hardware & tubing.

Check that the air supply in the empty tank is approximately 7 psi. Adjust if necessary.

To assure you the highest level of purity, the 5 Micron Sediment Cartridge, GAC Cartridge and Reverse Osmosis Membrane have been included separately in special packaging.

The proper method of installation is outlined below.

Installation of the 5 micron Sediment Pre-filter Cartridge

Completely unscrew and remove the "Pre-filter" housing from the assembly. Remove the protective film from the Sediment Cartridge. Carefully center the cartridge in the housing before reassembling. As you reassemble the housing to the system make sure the cartridge is centered on both the filter housing head and the housing itself. Once tight, the "Pre-filter" label on the filter housing should be centered on the front of the assembly.

Installation of the Carbon Block Cartridges

The Carbon Block Cartridge(s) is/are installed in the same manner as outlined above for the "Pre-filter".

Installation of the Reverse Osmosis (RO) Membrane

The RO Membrane has also been shipped to you separately. Remove the tubing from the end cap of the membrane housing, and unscrewed the end cap, insert the membrane as illustrated below. The O-rings on the product water tube of the membrane MUST FULLY SEAT in the membrane housing for proper operation. Also make sure that the Brine Seal on the membrane seals with no gaps or wrinkles inside the membrane housing. Once the membrane is installed, replace the end cap and re-connect the tubing.



To insure that all the special preservative is flushed from the system before use, DO NOT use the first two tankfuls of water produced by the system.

SECTION IV: Installation Steps

All plumbing should be done in accordance with state and local plumbing codes.

NOTE Some codes may require installation by a licensed plumber; check with the local plumbing authority prior to installation.

In restricted under-sink areas, it may be easier to install the faucet first. Allow adequate tubing lengths for any final component position.

A. Install The Faucet

NOTE For Faucet Assembly Diagram, please see Figure 2, below.

Under counter installations generally require that the faucet is installed with the built in air gap connected. In basement installations, the built in air gap does not have to be used if one is provided elsewhere in the drain line.

A non air gap faucet, which requires a smaller 9/16" mounting hole, is available from the factory to make basement installations easier.

If the sink already has a hole provided that can accommodate the RO faucet, then no drilling is required and you can proceed to the section on mounting the faucet.

NOTE

Sprayers can be disconnected to provide a suitable hole for the RO faucet. A pipe cap or plug will be required to seal the sprayer connection.

1. Make The Faucet Mounting Hole

IMPORTANT

It is mandatory that safety glasses be worn during sink hole drilling operations to prevent eye injury.

Before starting the hole making operation, always check below the sink so that nothing interferes with mounting the faucet such as reinforcing ribs, support brackets or cabinet construction.

Stainless Steel Sink, Air Gap or Non Air Gap Faucet:

Recommended tools:

- Center punch
- Variable speed drill and high speed drill bits
- Greenlee chassis punch 7/8" hole size (alternate 9/16" size may be used for non air gap faucet)
- Protective gloves

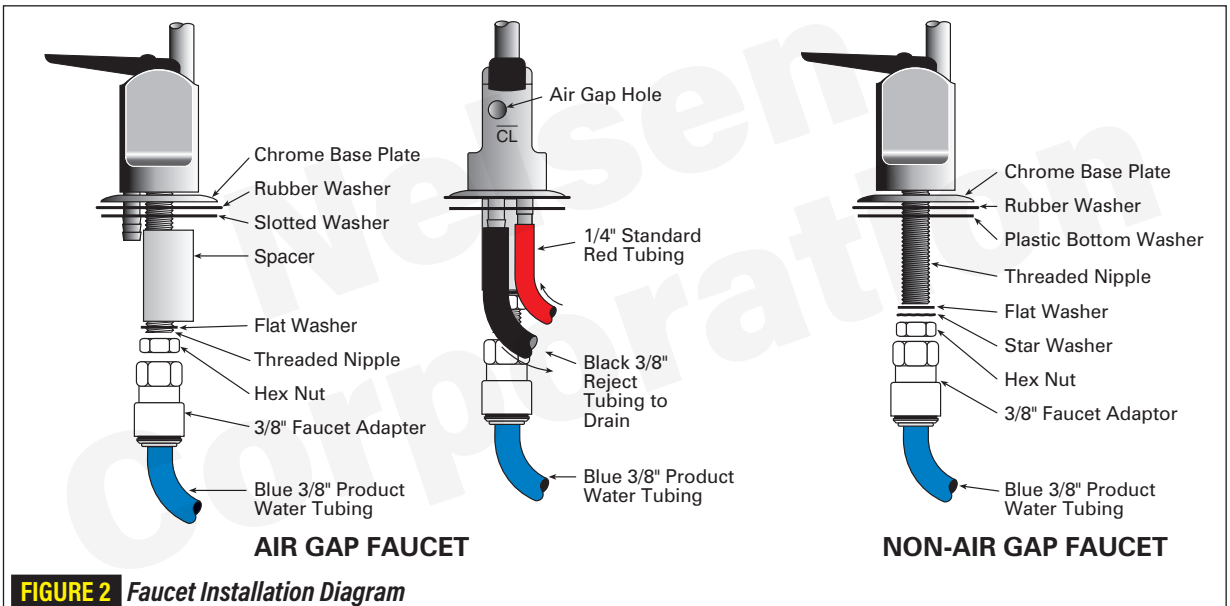

Procedure:

- Center punch a small indent at the desired faucet location.
- Slowly drill the required pilot hole for the chassis punch.
- Set up the chassis punch per instructions and tighten nut to cut the desired hole size.
- Clean up sharp edges with a file if necessary.

Porcelain/Enamel/Ceramic on Sheet Metal or Cast Iron Base; Faucet with or without Air Gap Module:

Recommended tools:

- Variable speed drill
- Relton porcelain cutter tool set 7/8" size (alternate 9/16" size may be used for air gap or non air gap faucet)
- Plumber's putty

It is important to understand what is involved in this procedure. First, the glassy layer of porcelain must be penetrated through to the base metal. Second, a center disc of porcelain must be removed while protecting the surrounding porcelain against chipping or fracturing. Third, the base metal must be drilled through to complete the hole.

Proceed at your own risk to sink damage.

Procedure:

- Mark the center for the 7/8" hole.
- Form a shallow putty dam around hole area and fill with enough water to lubricate carbide drill bit.
- Carefully drill pilot hole through porcelain/enamel and base metal using carbide type pilot drill.

IMPORTANT

Always operate drill with light pressure at slow speed (300-400 rpm)

- Insert pilot tip of spring-loaded porcelain cutter into pilot hole.
- Drill porcelain/enamel using spring-loaded porcelain cutter, making certain a complete ring has been cut through the porcelain/enamel to the metal base.
- Change to the metal cutter. With slow speed and light pressure, cut away the inner porcelain/enamel disc down to base metal. Make certain that the cutter does not touch outer rim of the cut porcelain/enamel. Continue with this bit to cut through metal until sink has been completely penetrated.

IMPORTANT

When using a porcelain cutter it is critical to take precautions that it is always in a sharpened condition. Dull cutters are known to chip sinks.

2. Mount The Faucet:

NOTE

For Basement Installation See Figure 7, Page 19.

Under Counter Installation with Air Gap Faucet:

- Familiarize yourself with all components shown in the air gap faucet diagram.
- Disassemble hardware from the threaded nipple, except for chrome base plate and rubber washer.

NOTE

Rubber washer may be replaced with bead of plumber's putty for neater appearance.

- Connect length of standard red 1/4" tubing to smaller barb on air gap faucet. Push on firmly until it seats.
- Connect length of black 3/8" tubing to larger barb on air gap faucet. Push on firmly until it seats.
- Feed the air gap tubing and threaded nipple through sink/counter mounting hole and orient the faucet as discussed with the customer.
- From below sink/counter assemble the white spacer (open end up, open side toward air gap), flat washer and hex nut on threaded nipple and tighten by hand.
- Back off on hex nut just enough to slide slotted washer between white spacer and underside of sink/counter (with open side of slotted washer closest to air gap tubes)
- After rechecking faucet orientation, tighten hex nut (9/16" wrench or deep socket) until faucet feels secure.
- From above the sink make any minor orientation corrections by turning the faucet with a padded adjustable wrench.

NOTE

Flats on chrome faucet may be used for tightening with an adjustable wrench. Use care not to mar faucet finish.

B. Install the Feed Water Valve and Tubing

Your RO system was supplied with either a Self Tapping Saddle Valve or an Angle Stop Adaptor.



1/4 Turn Angle Stop Valve - These valves have been designed to allow temporary servicing of downstream equipment and must only be used in the fully open or fully closed position. The Angle Stop Adapter attaches to the cold water supply under the sink. Refer to Figure 4. If necessary, refer to the diagrams on page 20 for the correct use of the quick connect fittings.

- 1) Shut-off water supply at brass/chrome supply valve.
- 2) Disconnect riser from brass/chrome supply valve.
- 3) Ensure that the sealing gasket is fully inserted into the Angle Stop Valve female thread.
- 4) Install Angle Stop Adapter Valve on supply valve.
- 5) Connect the riser to the Angle Stop Adapter Valve.
- 6) Fully insert tubing into the quick connect side of the valve.
- 7) Open valves and check for leaks.

Self-Piercing Saddle Valve - Designed for use with 3/8" to 1/2" OD soft copper supply tubing (plain or chrome) and rigid metal pipe (see below). Do not use with flexible ribbed supply

tubing which has too thin a wall thickness and requires special hardware. If necessary, refer to the diagrams on page 19 for the proper use of the quick connect fittings.

Soft Copper Tubing Installations:

- 1) Turn off cold water valve under the sink, or main valve for the house.
- 2) Before installing saddle tapping valve, make sure piercing lance does not protrude beyond rubber gasket.
- 3) Assemble saddle tapping valve on copper tubing. See Figure 5.
- 4) To pierce soft copper tube, turn handle clockwise until it is firmly seated. The valve is closed in this position.

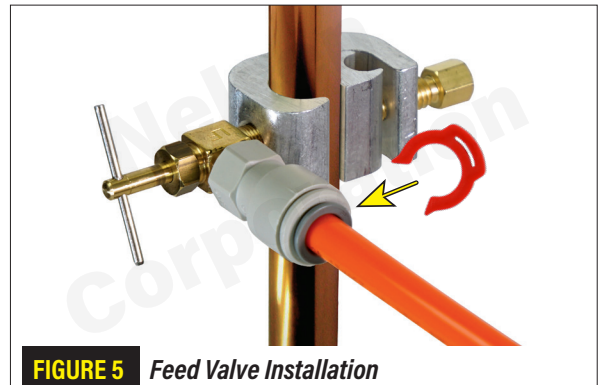

- 5) Install Locking Clip
- 6) Turn on main supply valve to pressurize cold water line. Check for leaks. With a wrench snug nut/seal around valve stem.

NOTE For basement installations the existing orange feed water tubing may have to be longer to reach feed valve.

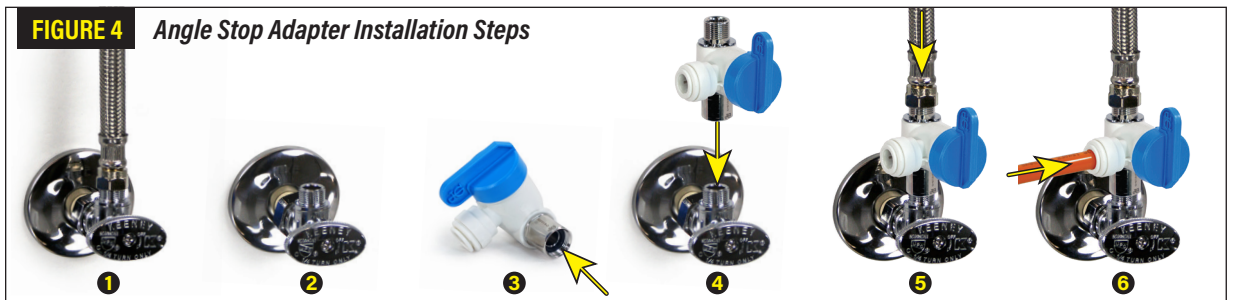

- 6) Connect one end of the orange tubing to the feed water valve using brass compression nut, insert and plastic sleeve.

Rigid Metal Pipe Installations:

- 1) Turn off cold water supply valve and drain the line to prevent spillage.
- 2) Drill 3/16" hole at the desired location. To prevent shock hazard, use a battery operated drill.
- 3) Before installing saddle tapping valve, make sure piercing lance does not protrude beyond rubber gasket.
- 4) Assemble saddle tapping valve on copper tubing. See Figure 5.
- 5) Turn saddle valve handle clockwise to close valve. With a wrench tighten nut/seal around valve stem.
- 6) When you wish to open valve and supply cold water to the unit, turn valve handle counterclockwise.
- 7) Connect one end of the orange tubing to the feed water valve using brass compression nut, insert, and plastic sleeve.

NOTE For basement installations the existing orange feed water tubing may have to be longer to reach feed valve.

C. Pre Fill and Sanitize the Storage Tank

Pre filling the tank is always recommended so there is pressure to check for leaks and several gallons of water to flush carbon post-filter. It is important to use a high quality sanitizer (such as ProProducts *Sani-System*) when pre filling tank so the solution can sanitize the tubing, fittings, and faucet at the time of installation and startup. Refer to Page 15 Changing Filters for additional information on sanitizing.

- 1) Insert free end of orange feed water tubing into the quick connect fitting on the storage tank.
- 2) Open feed water valve and tank valve and allow tank to fill (about 3 minutes).
- 3) Turn off feed water valve and tank valve and set tank aside (15 minutes min).

D. Install the Drain Connection

NOTE For Basement Installation See Figure 7, Page 19.

Under counter Installations:

IMPORTANT Before starting this procedure, inspect the condition of the drain piping, especially in older homes where the traps and tailpieces can be deceptively thin and frail. If in poor condition, the condition should be remedied.

The drain saddle assembly is designed to fit around a standard 1-1/2" OD drain pipe.

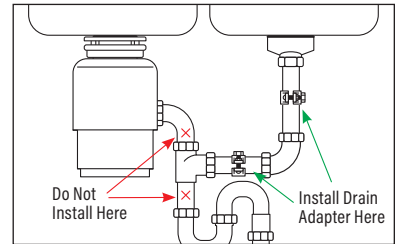

The drain saddle should always be installed above

(before) the trap and on the vertical or horizontal tailpiece. Never install the drain saddle close to the outlet of a garbage disposal or plugging of the RO drain line may occur, as shown above.

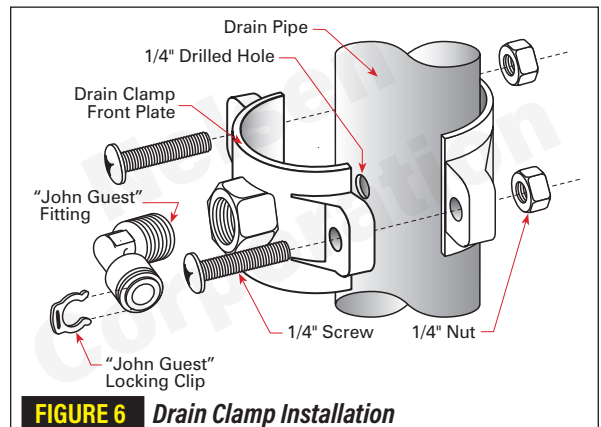

FIGURE 6 Drain Clamp Installation

- 1) Position threaded half of drain saddle at selected location and mark the spot through the opening. See diagram.
- 2) Drill a 1/4" hole at the marked spot through one side of drain tailpiece.
- 3) Position both halves of drain saddle on drain pipe so threaded opening lines up with the hole in drain pipe.
- 4) Use bolts and nuts to clamp drain saddle onto drain pipe. Do not over tighten and make sure there is equal space between saddle halves on each side. See diagram.
- 5) Wrap teflon tape on thread of quick connect fitting and tighten into drain saddle. Some systems include an integral Drain Saddle valve.

E. Make Initial Tubing Connections

NOTE

For Basement Installation See Figure 7, Page 19.

For Aqua Premier systems, some fittings were not installed at the factory to prevent breakage during shipping and will need to be installed prior to making tubing connections. An accessory kit is included with your system and includes special instructions showing the installation and connections needed to complete the RO assembly.



Under counter Installation:

- 1) It is advantageous to make some of the tubing connections at this time, since the under-sink work area is not so cramped and access to the components is easier. If necessary, refer to the enclosed diagram on use of the quick connect plastic fittings.
- 2) The orange 3/8" tubing should already have been connected to the feed water valve.
- 3) Tighten 3/8" plastic quick connect fitting onto threaded faucet nipple. No Teflon tape is required to make an effective seal. It may be necessary to hold faucet from turning while tightening fitting.
- 4) Route black 3/8" tubing (Air Gap Faucet) from faucet air gap to drain saddle so that it slopes continuously downward without loops or low spots. Cut to proper length and connect to quick connect drain fitting.

F. Install the Purification Assembly & Storage Assembly

NOTE

For Basement Installation See Figure 7, Page 19.

Under counter Installation:

The RO assembly is usually mounted to the right or left sink cabinet sidewall, taking into consideration the space available and the tank location. Generally, the tank is placed in the rear of the cabinet while the purification assembly is positioned toward the front for cartridge accessibility.

To mount the purification assembly elevate at least 2" off the cabinet floor and, while keeping level, mark the location of the mounting holes on cabinet sidewall. Make small pilot

holes with an awl or drill and screw in the two mounting screws, leaving just enough protruding to allow bracket mounting slots to slide over them.

NOTE

If the cabinet sidewalls are not of solid construction, the purification assembly can be set on the cabinet floor and held against the sidewall with the mounting screws.

The tank may be oriented either vertically or horizontally. It is generally placed to the rear of the cabinet but can be set in the front center (between the sink basins) for ease of access if space permits.

G. Make Final Tubing Connections

NOTE

For Basement Installation See Figure 7, Page 19.

With all of the components in place, the final tubing connections can be made. When routing tubing between components, several guidelines should be observed.

- Tubing runs should generally follow the contour of the cabinets rather than interfere with the cabinet storage area.
- Strive for neatness and an orderly tubing "flow" using fasteners (e.g. insulated staples) to secure the tubing. Cut tubing to the desired length.
- Arrange the tubing so there are no sharp bends and leave some "play" in the tubing for ease of servicing.
- Try to keep the tubing from the purification assembly to the tank and faucet as short as practical for good flow. If necessary, refer to the enclosed diagram on use of the quick connect plastic fittings.

Undersink Installation

- 1) Connect orange 3/8" tubing from feed water valve to the "Feed" connection on purification assembly.
- 2) Connect yellow 3/8" tubing from purification assembly to tank.
- 3) Insert end of red 1/4" tubing leading from faucet into drain elbow. See figure 1, page 2.
- 4) Connect blue 3/8" tubing from purification assembly to quick connect fitting on faucet.

H. Install Ice Maker Hookup (optional)

The RO drinking water appliance can be connected to any standard refrigerator ice maker or ice maker/water dispenser. It should never be connected to a commercial type bar ice maker.

Hooking up an ice maker involves connecting a tee with shut off valve into the blue 3/8" faucet tubing and routing tubing over to the refrigerator. Hooking up to existing copper tubing is generally not recommended unless it is less than six months old. If copper tubing must be used, then installation of a small in-line carbon filter at the refrigerator connections is recommended.

Before turning off the existing tap water supply to a refrigerator ice maker, always shut off the ice maker first (usually by lifting the lever arm above the bin to the upper-most position). The ice maker should only be turned on again after the RO system has been drained several times and the tank has a full supply of water.

NOTE

Before any service is performed on the RO system, always turn off ice maker valve and the ice maker unit. Only turn on when system is operating and tank is full.

I. Start Up The System

- 1) Double check that all connections are secure.
- 2) Turn on feed water valve and check for leaks. If any leaks are noted, turn off valve and correct before proceeding.

NOTE

If a leak occurs at a quick connect fitting refer to Page 20 for correct usage.

- 3) Turn on storage tank valve and open faucet until a steady stream of water flows. Close faucet, wait at least 5 minutes and carefully check for leaks. Correct as necessary.

NOTE

When the system is first turned on, water may intermittently "spurt" from the air gap opening at side of air gap faucet. This is perfectly normal, and is caused by air trapped in the system. This will usually disappear within a short time.

J. Flush System of Preservative & Check Operation.

- 1) Lift faucet handle and allow tank to drain completely of sanitizing solution, preservative and carbon fines. Do Not Use This Water. When tank is empty, the faucet will steadily drip. This is the rate water is processed by the RO system.
- 2) With faucet handle in "up" position, measure the rate of the steady drip from spout. Use a graduated cylinder (in milliliters) and watch with a second hand to calculate approximate production in gallons per day (milliliters per minute X 0.38 = gpd). Proceed to check reject flow rate by disconnecting tubing at drain connection and measure as per above. The ratio should be a minimum of 2.5 (reject) to 1 (product).
- 3) Close faucet and re-inspect system for leaks. Instruct customer (or use special faucet tag supplied) to wait at least 4 hours and drain tank again. The water should be discarded as it may contain some preservative/disinfectant solution.
- 4) System should be ready to use as soon as the tank refills. If any objectionable taste is noticed after second tank draining, wait and drain tank the following day. Only at this time should an ice maker be turned on if one is connected to the system.

NOTE

If optional percent rejection is used and indicates service is required, several tank fulls of water may have to be used to completely flush excess TDS from the new Carbon Post-filter before the green light will show.

K. Clean Up & Paperwork

- 1) Clean up the work thoroughly.
- 2) Affix any special decals or stickers. Be sure to record the house pressure and TDS for service files.
- 3) Familiarize family members with the general operation of their new RO drinking water appliance. In particular, note the following on standard faucet:
 - The faucet handle positions, down for momentary flow, and up for continuous flow. Also note the moveable spout.
 - The location of the feed valve and tank shut off valve as well as the procedure for turning them off.
 - Review the many uses of the water (cooking, soups, juices, ice cubes, baby formula, pets, plants, etc.)
 - Review the recommended maintenance schedule as determined by local water conditions.

Section V: Appendix for Basement Installations

The following variations are generally required for basement installations:

A. Installing The Drain Connection

For basement installations, the drain saddle is generally not used. Instead, the RO reject line is routed so that it drains into a laundry sink, floor drain, or standpipe through an approved air gap. See Figure 7 on Page 17.

B. Mounting The Faucet

Air Gap Faucet

Follow the installation instructions given earlier in this manual. Do not hook up any air gap tubing to the faucet since an alternate air gap will be used elsewhere in the drain line.

Non Air Gap Faucet

- 1) Familiarize yourself with all components shown in the diagram of the non-air gap faucet.
- 2) Assemble only the chrome base plate and rubber sealing washer onto the threaded nipple. (Plumber's putty may be used in place of sealing washer for neater appearance)
- 3) Feed threaded nipple through sink/counter mounting hole (9/16" hole is adequate).
- 4) From below the sink/counter assemble plastic bottom washer, flat washer, star washer, and hex nut onto the threaded nipple. Hand tighten hex nut until faucet feels snug.
- 5) After rechecking faucet orientation, tighten hex nut (9/16" wrench or deep socket) until faucet feels secure.

C. Making Initial Tubing Connections

- 1) A proper length of orange 3/8" feed water tubing should already have been connected to feed water valve with a brass compression nut, insert and plastic sleeve.
- 2) Tighten 3/8" quick connect fitting onto the threaded nipple. It may be necessary to hold faucet from turning while tightening fitting.
- 3) Connect proper length of blue 3/8" tubing to faucet fitting (See quick connect fitting instructions). Route tubing through the floor to the vicinity of the purification assembly location.

- 4) Route standard red 1/4" tubing from an appropriate drain connection (e.g. laundry sink, floor drain, stand pipe) to intended location of purification assembly. An air gap must be installed between outlet and drain connection.

D. Installing the Purification Assembly & Storage Tank

The purification assembly is generally mounted to the basement wall (using wall anchors) or to wood ceiling supports. To mount the purification assembly, keep bracket level and mark the location of the mounting holes. Install wall anchors and/or mounting screws as required. Leave screw heads protruding to allow bracket mounting slots to slide over them.

The tank may be oriented either vertically or horizontally and can be placed on a shelf, on the floor or suspended with sturdy brackets to the ceiling supports.

An effort should be made to minimize the distance between the tank and purification assembly to assure an adequate flow rate to the faucet.

E. Making Final Tubing Connections A

- 1) Connect orange 3/8" tubing from feed water valve to "FEED" connection on purification assembly.
- 2) Connect blue 3/8" tubing from faucet to the "TO FAUCET" connection on purification assembly.
- 3) Connect the yellow 3/8" tubing to the "TO TANK" connection on purification assembly. Connect the other end of the yellow 3/8" tubing to the storage tank.
- 4) Connect the red 1/4" drain tubing to the drain fitting on the purification assembly.

SECTION VI: Operation & Maintenance

A. Normal Operation

- 1) It is normal for the Total Dissolved Solids (T.D.S.) of the water to be higher than normal during the first 5 gallons of operation, this is due to the sanitizing solution and the new Post-filter. After this water is rinsed to drain, the removal rate should stabilize at a value greater than 75%. Water pressure affects the production rate and quality.
- 2) RO systems produce drinking water at relatively slow rates, it can take up to 8 hours or more to fill the holding tank. Normal operation is to let the Holding Tank fill with water and then draw water as is needed. When the

pressure in the Holding Tank falls to a given pressure (as the water is being used) the Automatic Shut Off Valve (A.S.O. Valve) will start water production and the system will refill the Holding Tank. When the Holding Tank is full and no water is being used, the A.S.O. Valve will automatically shut off the feed water to conserve water.

The more water that is used (up to the capacity of the system) the better the RO system will function. Utilize other uses for the water, such as flowers, pets and rinsing glassware.

After periods of non-use, such as a week's vacation, it is better to empty the holding tank and allow the system to produce fresh water for use. If the system is not used for 3-4 weeks or longer, it is a good idea to re-sanitize the system and to change the Activated Carbon and Sediment Filters.

B. Changing Filters

NOTE *This RO System contains filters which must be replaced at regular intervals to maintain proper performance. Use only factory approved filters.*

Please see Page 2 for the recommended interval for changing the filters. Local conditions may dictate more frequent changes.

Use a drip pan to catch any water that may spill when the Filter Housing are removed.

- 1) Close the Saddle Tapping Valve by turning fully clockwise and open the Dispensing Faucet by lifting the handle. Allow the Holding Tank to empty.
- 2) Loosen and remove the appropriate Filter Housing. Discard the cartridge(s).
- 3) Wash the inside of the Housing(s) using a mild detergent and a soft cloth. Do not use abrasive cleaners or pads. Thoroughly rinse all soap from the housing before reassembly.

- 4) To sanitize the system and replace the filter cartridge(s):

NOTE *The system should be sanitized before installing the Post-filter Cartridge.*

- a) Use a good quality sanitizer product such as Pro Products Sani-System for ROs. Sani-System Liquid Sanitizer Concentrate is the only EPA registered & NSF approved sanitizer for use in water softeners and reverse osmosis units.
- b) Follow the directions on the sanitizer for proper sanitizing of the RO assembly.
- c) Shut off water supply to RO unit and remove membrane and all filters. Use rubber gloves and store filters and membranes in water to prevent damage.
- d) Open pure water faucet and depressurize system
- e) Pour entire packet of Sani-System directly into the first main housing unit. Make sure pure water faucet is closed and turn on water supply.
- f) Allow system to fill with water. The time will vary depending on the water pressure. However, the system should be full within 5 – 10 minutes without the filters or membrane. Flush the system two times.
- g) Replace or re-install membranes and all filters.
- h) Check for leaks.



SECTION VII: Technical Data

A. Water Quality

- 1) Water quality is normally measured with a special meter that measures the water ability to conduct electricity. The more dissolved solids in the water, the higher the conductivity. The results are usually reported in Parts per Million (ppm) or Milligrams per Liter (mg/l) of Total Dissolved Solids (T.D.S.). (Although technically they are not exactly equal, in most discussions ppm = mg/l.)
- 2) RO Membranes are rated by the amount of dissolved solids that are rejected. This rating is a ratio of the T.D.S. in the product water and is reported as Percent Rejection. If the feed water contained 100 ppm of T.D.S. and the product water contained 10 ppm of T.D.S., 90 ppm have been rejected and the reject ratio is 90%.

$$\text{Percent Rejection} = \frac{\text{Feed T.D.S.} - \text{Product T.D.S.} \times 100\%}{\text{Feed T.D.S.}}$$

B. Water Quantity

- 1) Water quantity is termed Flux or Product Water Rate and is measured as the amount of water produced in one day. It is reported as Gallons per Day (gpd) or as Milliliters per Minute (ml/min).
- 2) The flow of water to drain is the Reject Water Rate and is measured as Gallons per day (gpd) or Milliliters per Minute (ml/min).

$$\text{Milliliters per minute} \times .38 = \text{gallons per day}$$

EXAMPLE

The drain flow will fill a graduated cylinder to the 105 ml mark in one minute.

$$105 \text{ ml/min.} \times .38 = 40 \text{ gpd}$$

If the container available measures ounces, use the following conversion:

$$\text{Ounces per minute} \times 11.2 = \text{gallons per day}$$

- 3) The Reject Ratio is the amount of water produced compared to the amount of water flowing to drain.

$$\text{Reject Ratio} = \frac{\text{Reject Rate}}{\text{Product Rate}}$$

- 4) The Percent Recovery is another way to measure the amount of water produced as compared to the amount actually used.

$$\% \text{ Recovery} = \frac{\text{Product Rate} \times 100\%}{\text{Feed Rate}}$$

NOTE

The total flow or feed water rate into the system is the sum of the product flow and the drain flow.

C. Water Pressure and Temperature

Most RO Membranes are rated at a standardized condition of 77°F (25°C) and 60 psi (414 kPa) discharging to atmospheric pressure.

Product water quality and quantity greatly depend upon the Net Pressure Differential (Δp) across the RO Membrane. This pressure differential is a summation of the feed water pressure at the Membrane, which tries to push the water through, the pressure in the Holding Tanks, which tries to push the water backwards and the osmotic pressure, which also tries to push the water backwards.

The Osmotic Pressure is in proportion to the dissolved minerals in the water and can be approximated by 1 psi for each 100 ppm of T.D.S.

The higher the net pressure differential, the higher the quantity and quality of water produced.

Some loss of production when using a pressurized Holding Tank is normal.

Feed Water Temperature also has an affect on water production. The lower the temperature, the lower the quantity of water produced (see Table 3, page 13)

$$\begin{aligned} \text{Water Production Rate} &= \text{Rated Flow} \\ &\times \text{Pressure Correction} \\ &\times \text{Temperature Correction} \end{aligned}$$

FIGURE 7 *Booster Pump Installation Diagram*

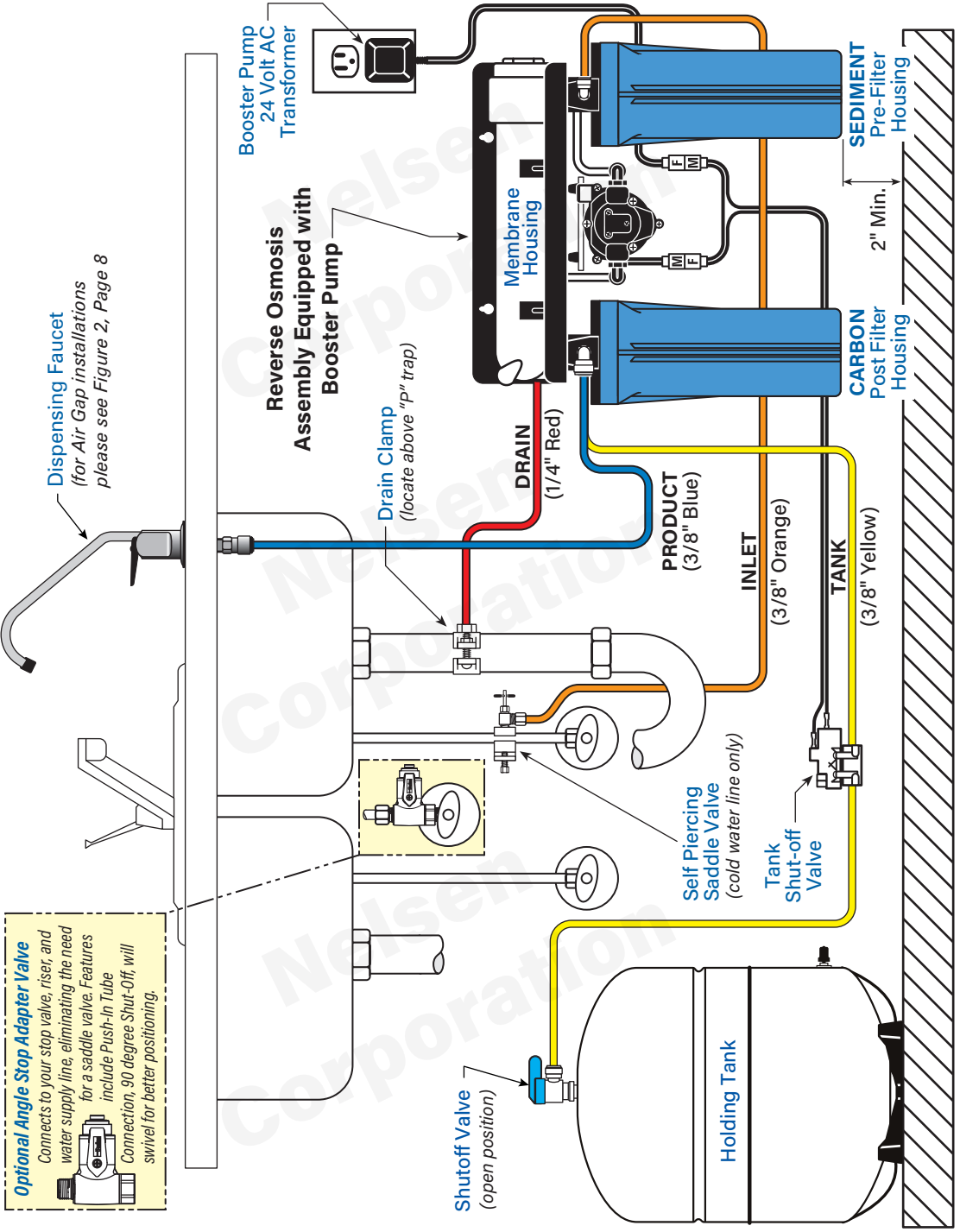

TABLE 1: Pressure Correction factors for Thin Film Composite (T.F.C.) Membrane Production Rate

Pressure Δpsi	ΔkPa	Correction Factor	Percent Rejection	Pressure Δpsi	ΔkPa	Correction Factor	Percent Rejection
10	69	.17	84	60	414	1.00	94
15	103	.25	88	65	448	1.08	94
20	138	.33	90	70	483	1.17	95
25	172	.42	92	75	517	1.25	95
30	207	.50	93	80	552	1.33	95
35	241	.58	93	85	586	1.42	95
40	276	.67	94	90	621	1.50	96
45	310	.75	94	95	655	1.58	96
50	345	.83	94	100	689	1.67	96
55	379	.92	94				

To adjust from 60 psi (414kPa) to another pressure multiply the production rate by the correction factor. To adjust from given pressure to standard conditions divide by the factor.

*Percent rejection of Total Dissolved Solids

SECTION VIII: Booster Pump Appendix

The booster pump consists of the pump, transformer unit and the tank shut-off switch. The tank shut-off switch will shut down the pump when continuous water production is not necessary, as when the tank is full, so as not to prematurely burn out the pump. The AC transformer steps down the primary household 110 voltage to a safe 24 volts.

NOTE

For typical Booster Pump Installation
See Figure 7, Page 17.

Installation of the Tank Shut-Off Valve

- Turn off the water at the needle valve if on.
- Cut the yellow 3/8" O.D. flexible tubing with a clean square cut to insure proper seal and to avoid misalignment of the compression fitting connectors.
- Insert tubing into pump ports and tighten the fittings.
- Open the feed-water valve.
- Check fittings for leaks.
- Check the transformer voltage and plug into appropriate receptacle.
- Allow water to circulate to relieve entrapped air.

The pump will now build pressure. Operating pressure will vary with membrane flow rate, flow restrictor flow rate, feed-water pressure and line voltage. Typical operating pressure is constant, between 80 - 110 psi.

If the flow restrictor is too small, or the R.O. system is clogged, an internal pump by-pass mechanism limits the output pressure to "feed water pressure plus 80 psi". As pump output pressure approaches "feed-water pressure plus 80 psi", a slight squeaking sound may be heard. This "sound" can be avoided by eliminating the system clogging.

Technical Notes

Membrane production rate is rated at 60 psi; the same membrane operating at 90 psi or 100 psi will increase production rate by 30% - 40%.

Membrane rejection rate is rated at 60 psi; the same membrane operating at 90 psi - 100 psi will increase reject rate by 5% - 10% depending on the system "back-pressure".

Pump orientation is recommended to be in any position **except** with the pump head pointed down.

TABLE 2: Temperature Correction Factors for Thin Film Composite (T.F.C.) Membrane Production Rate

Temperature °F	(°C)	Correction Factor	Temperature °F	(°C)	Correction Factor
50.0	(10.0)	1.711	68.4	(20.2)	1.180
50.5	(10.3)	1.692	68.9	(20.5)	1.168
51.1	(10.6)	1.673	69.4	(20.8)	1.156
51.6	(10.9)	1.654	70.0	(21.1)	1.144
52.2	(11.2)	1.636	70.5	(21.4)	1.132
52.7	(11.5)	1.618	71.1	(21.7)	1.120
53.2	(11.8)	1.600	71.6	(22.0)	1.109
53.8	(12.1)	1.582	72.1	(22.3)	1.097
54.3	(12.4)	1.564	72.7	(22.6)	1.086
54.9	(12.7)	1.547	73.2	(22.9)	1.075
55.4	(13.0)	1.530	73.8	(23.2)	1.064
55.9	(13.3)	1.513	74.3	(23.5)	1.053
56.5	(13.6)	1.496	74.8	(23.8)	1.042
57.0	(13.9)	1.480	75.4	(24.1)	1.031
57.6	(14.2)	1.464	75.9	(24.4)	1.021
58.1	(14.5)	1.448	76.5	(24.7)	1.010
58.6	(14.8)	1.432	77.0	(25.0)	1.000
59.2	(15.1)	1.417	77.5	(25.3)	0.991
59.7	(15.4)	1.401	78.1	(25.6)	0.982
60.3	(15.7)	1.386	78.6	(25.9)	0.974
60.8	(16.0)	1.371	79.2	(26.2)	0.965
61.3	(16.3)	1.356	79.7	(26.5)	0.957
61.9	(16.6)	1.342	80.2	(26.8)	0.948
62.4	(16.9)	1.327	80.8	(27.1)	0.940
63.0	(17.2)	1.313	81.3	(27.4)	0.932
63.5	(17.5)	1.299	81.9	(27.7)	0.924
64.0	(17.8)	1.285	82.4	(28.0)	0.915
64.6	(18.1)	1.272	82.9	(28.3)	0.908
65.1	(18.4)	1.258	83.5	(28.6)	0.900
65.7	(18.7)	1.245	84.0	(28.9)	0.892
66.2	(19.0)	1.232	84.6	(29.2)	0.884
66.7	(19.3)	1.219	85.1	(29.5)	0.877
67.3	(19.6)	1.206	85.6	(29.8)	0.869
67.8	(19.9)	1.193			

To Adjust from 77° F (25° C) to another temperature, multiply the production rate by the correction factor. To adjust from a temperature to standard conditions divide by the factor.

FIGURE 8

General Basement Installation Diagram

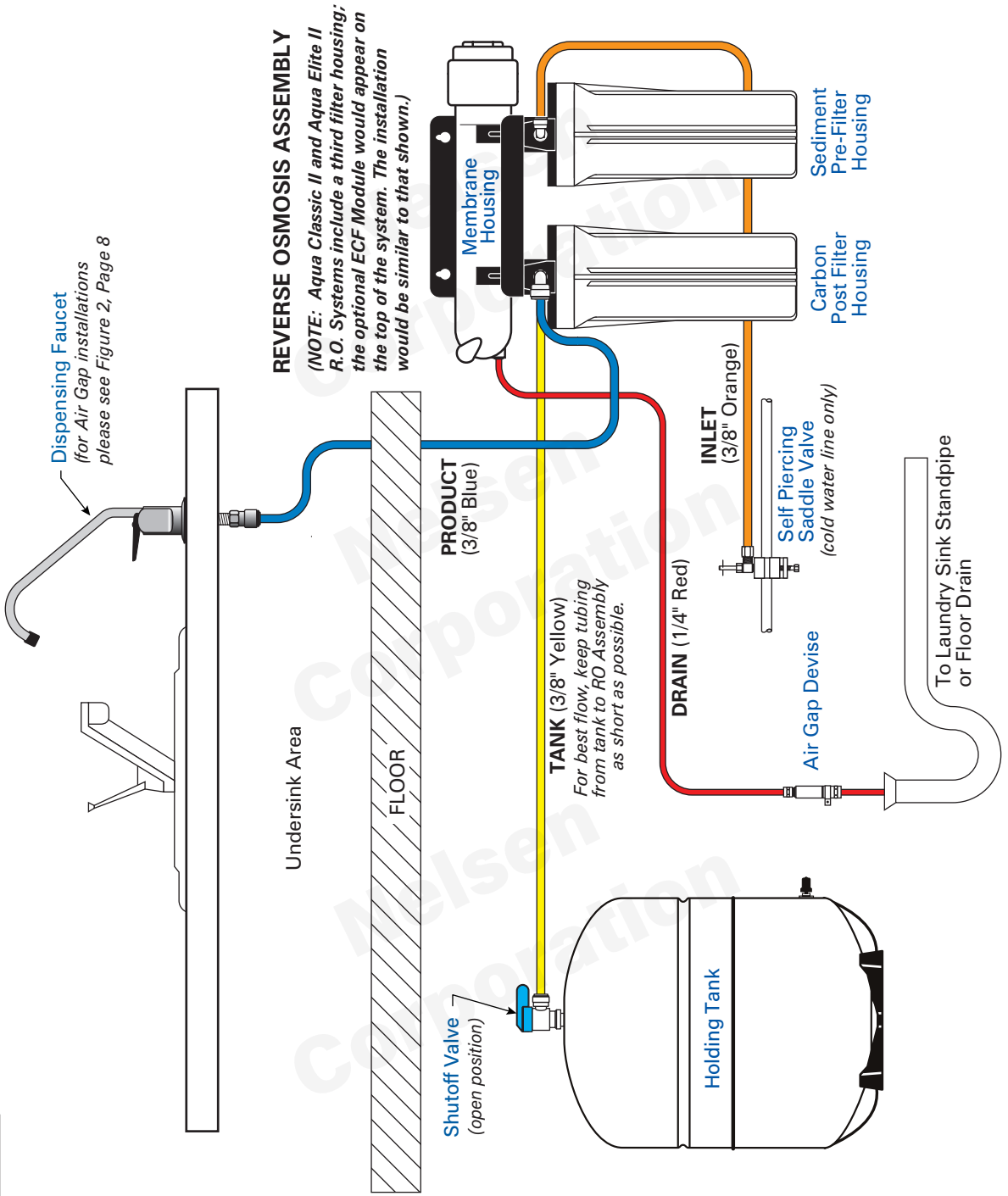

REVERSE OSMOSIS ASSEMBLY

(NOTE: Aqua Classic II and Aqua Elite II R.O. Systems include a third filter housing; the optional ECF Module would appear on the top of the system. The installation would be similar to that shown.)

How to use the "Quick Connect" fittings.

Your new Reverse Osmosis Drinking Water Appliance is outfitted with the new generation of user-friendly "Quick Connect" push-in fittings. Proper use of the fittings is shown in the diagrams. It is important that the tubing selected for use with these connectors be of high quality, exact size and roundness, and with no surface nicks or scratches. If it is necessary to cut the tubing, use a plastic tubing cutter or sharp razor knife. Make a clean, square cut. An red locking clip is installed in certain fittings to provide extra security. Remove this clip first before trying to remove tubing by sliding away from fitting. Should a leak occur at a fitting, the cause is usually defective tubing.

To fix:

- Relieve pressure
- Release tubing
- Cut off at least 1/4" from end
- Reattach tubing
- Confirm connection is leak free

To Attach Tubing

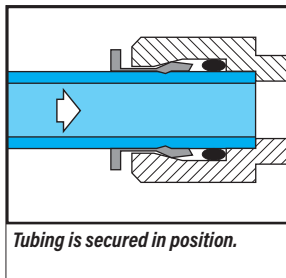
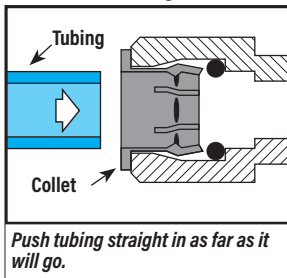

To Release Tubing

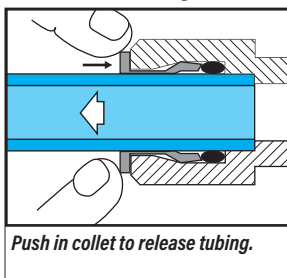

Locking Clip

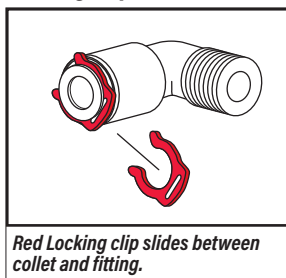

Reverse Osmosis - How Does it Work

Reverse osmosis (RO) is a separation process that uses pressure to force a solvent through a membrane that retains the solute on one side and allows the pure solvent to pass to the other side. More formally, it is the process of forcing a solvent from a region of high solute concentration through a membrane to a region of low solute concentration by applying a pressure in excess of the osmotic pressure. This is the reverse of the normal osmosis process, which is the natural movement of solvent from an area of low solute concentration, through a membrane, to an area of high solute concentration when no external pressure is applied. The membrane here is semipermeable, meaning it allows the passage of solvent but not of solute.

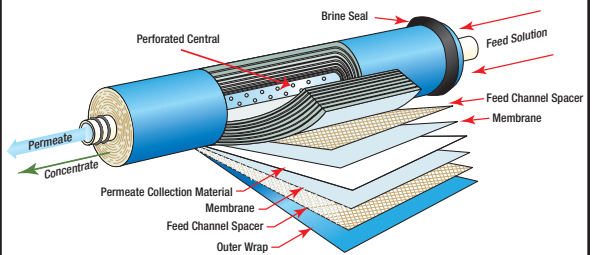

Nominal Rejection Characteristics of Thin Film Composite Polyamide Membrane*

Ion	Symbol	% Rejection	Ion	Symbol	% Rejection
Aluminum	Al + 3	97 – 98	Magnesium	Mg + 2	95 – 98
Ammonium	NH ₄ +	85 – 95	Mercury	Hg + 2	95 – 97
Borate	B4O ₂ -2	30 – 50	Nickel	Ni + 2	97 – 98
Boron	B	60 – 70	Nitrate	NO ₃ -	90 – 95
Bromide	Br -	93 – 96	Phosphate	PO ₄ -3	95 – 98
Cadmium	Cd + 2	93 – 97	Polyphosphate		96 – 98
Calcium	Ca + 2	95 – 98	Potassium	K +	92 – 96
Chloride	Cl -	92 – 98	Silica	Si	85 – 90
Chromate	CrO ₄ -2	85 – 95	Silicate	SiO ₂ -2	92 – 95
Copper	Cu + 2	96 – 98	Silver	Ag +	95 – 97
Fluoride	F -	93 – 95	Sodium	Na +	92 – 98
Iron	Fe + 2	96 – 98	Sulfate	SO ₄ -2	96 – 98
Lead	Pb + 2	95 – 98	Thiosulfate	S ₂ O ₃ -2	97 – 98
Manganese	Mn + 2	97 – 98	Zinc	Zn + 2	97 – 99

* The above percent of rejection is for reference only and not to be construed as chemistry, temperature, and TDS are not constant in each water supply.

Nelsen Corporation Limited Warranty

Nelsen Corporation ("Nelsen") is pleased to provide you this limited warranty as described below (the "Limited Warranty").

Limited Warranty

Subject to the terms of this Limited Warranty, Nelsen warrants to the original buyer of its Aqua Classic, Aqua Elite and Aqua Premier Reverse Osmosis Drinking Water System product (the "Product") from a Nelsen authorized dealer ("Buyer") that, except as otherwise provided in this Limited Warranty, the Product will be free from defects in material or workmanship for a period of one (1) year after the date of original installation. In addition, individual components of the Product may be covered by the original manufacturer's warranty. This Limited Warranty shall apply only if the Product is installed, operated and maintained in strict accordance with Nelsen's or the manufacturer's guidelines and other legal requirements. This Limited Warranty shall not cover and shall be null and void with respect to any goods that, in Nelsen's discretion, are: (a) modified after sale, (b) improperly installed, stored, used or handled, (c) abused or misused or otherwise damaged due to fire, lightning, power surges or other acts of God or exposure to freezing or hot water or the effects of normal wear and tear.

Additional Conditions

- This limited warranty only covers the Product if installed and used for residential purposes. Any Product installed or used for commercial or industrial applications are not subject to this limited warranty.
- Water pressure and temperature must not exceed manufacturer guidelines.
- This limited warranty does not cover the disposable sediment and carbon cartridges whose service life depends on feed water conditions.
- This limited warranty will not apply to any membrane if the required pre-filter conditions to the membrane are not followed.

Warranty Claims

All Limited Warranty claims hereunder shall be submitted by Buyer to Nelsen dealer who sold the Product in writing and shall include the Buyer's name, address, telephone number, date of purchase of the Product, receipt evidencing proof of purchase and a copy of this Limited Warranty. All Limited Warranty claims shall be submitted to Nelsen at the following address: 3250 Barber Rd. Norton, OH 44203. Nelsen or its dealer will investigate the claim. Buyer must fully cooperate in investigating and evaluating the claim, including, without limitation, providing additional information upon request. TO BE ELIGIBLE FOR LIMITED WARRANTY COVERAGE, BUYER MUST SUBMIT A CLAIM WITHIN SIXTY (60) DAYS OF THE DATE THE ALLEGEDLY DEFECTIVE PRODUCT IS FIRST DISCOVERED BY BUYER.

Repair or Replacement/Credit

Subject to the conditions and limitations herein, if Nelsen determines that a Product does not conform to this Limited Warranty, Nelsen will repair or replace the defective Product. Any replaced Products, or any parts therein, shall be retained by and become the property of Nelsen.

If Nelsen determines that repair or replacement of defective goods is not commercially practicable, Nelsen will issue a credit in favor of Buyer in an amount not to exceed the purchase price of the Product. Notwithstanding anything to the contrary contained herein, this Limited Warranty does not cover any cost or labor associated with the removal or re-installation of the replacement Product or any shipping costs associated with the returned Product or repaired or replacement Product.

Eligibility/Non-Transferable

This Limited Warranty applies only to Buyer if the Products are purchased from a Nelsen authorized dealer. This Limited Warranty is personal to Buyer, and may not be assigned or otherwise transferred by Buyer. Any attempt to transfer this Limited Warranty shall be null and void and not recognized by the Company.

Disclaimer of Other Warranties/Limitation on Liability

EXCEPT AS PROVIDED ABOVE AND TO THE EXTENT PERMITTED BY LAW, THERE ARE NO OTHER REPRESENTATIONS OR WARRANTIES WITH RESPECT TO THE PRODUCT, EITHER EXPRESS OR IMPLIED, WRITTEN OR ORAL, OR ARISING UNDER CUSTOM OF TRADE, INCLUDING, WITHOUT LIMITATION, THE IMPLIED WARRANTIES OF MERCHANTABILITY AND FITNESS FOR A PARTICULAR PURPOSE. NO REPRESENTATIONS OR WARRANTIES AT ANY TIME MADE BY ANY EMPLOYEE, AGENT OR REPRESENTATIVE OF NELSEN SHALL BE EFFECTIVE TO VARY OR EXPAND ANY WRITTEN WARRANTY OR THE TERMS HEREOF. TO THE EXTENT A WAIVER OF IMPLIED WARRANTIES IS PROHIBITED BY LAW, ANY IMPLIED WARRANTIES SHALL BE LIMITED TO THE DURATION OF ANY WRITTEN WARRANTY PROVIDED BY NELSEN.

In no event shall Nelsen be liable to Buyer or to any third party for consequential, incidental, special or punitive damages, or for lost profits or loss of use, resulting from or in any manner related to the goods, their delivery, non-delivery, use, or inability to use the same, whether such damages be claimed under contract, tort or any other legal theory.

Waiver of Class Action

ANY AND ALL CLAIMS ASSERTED BY BUYER OR ANY OTHER PERSON OR ENTITY SHALL BE RAISED IN SUCH PARTY'S INDIVIDUAL CAPACITY AND MAY NOT BE RAISED AS A PLAINTIFF OR CLASS MEMBER IN ANY PURPORTED CLASS OR REPRESENTATIVE PROCEEDING.

Applicable Law

This Limited Warranty shall be interpreted and governed under the laws of the State of Ohio without giving effect to the choice of law rules thereof. Nelsen and Buyer agree to submit to the jurisdiction of the state or federal courts located in Summit County, Ohio for purposes of resolving any dispute or claim arising in connection with a transaction.

